

SEACON[®]

UNDERWATER ELECTRICAL AND FIBER OPTIC CONNECTORS



OPTI-CON



UNDERWATER OPTICAL HYBRID DRY-MATE CONNECTORS



MANAGEMENT SYSTEM APPROVED IN ACCORDANCE WITH ISO 9001.



UNDERWATER OPTICAL HYBRID DRY-MATE CONNECTORS

INTRODUCTION

With an increase in the use of fiber optics throughout the subsea industry, SEACON (europe) Ltd is pleased to introduce its standard, drymate, fiber optic hybrid connector range.

OPTI-CON is a unique design that allows the customer to choose any combination of optical and electrical configurations to suit their particular needs. The manufacture of all parts in house ensures that each connector is supplied with the highest of standards. This connector range is manufactured from 316L Stainless Steel as standard, but other materials are available upon request.

AVAILABILITY

OPTI-CON offers interchangeable electric or optic contacts and is available in 5 shell sizes from 1 to 20 contact configurations, oil filled or over-molded to any type of cable (subject to test sample). Pressure rated to 7,500 psi (5,200m water depth) this series is offered in a variety of fiber types from single-mode to multi-mode (9/125, 50/125 or 62.5/125) with optical insertion losses of <0.5dB, typically <0.3dB.

TESTING

Due to the modular nature of the **OPTI-CON** series, testing has been conducted to simulate the extremes of operation, this means carrying out the qualification four times on each assembly as the options are: -

Electrical contact.

Multi-mode optical contact.

Single-mode optical contact.

Mixed optical (single and multi-mode) and electrical contacts.

- The electrical contacts have been tested to 1000 VDC with regard to shell and other conductors with a minimum Insulation Resistance of 1000 megohms.
- Mated single-mode optical contacts have been tested to 10,000 psi, including cycling, with recorded dB losses well under the 0.3dB acceptance. (Typically 0.2dB).
- Mated multi-mode optical contacts have been tested to 10,000 psi, including cycling, with recorded dB losses well under the 0.3dB acceptance. (Typically 0.2dB).
- Mated electrical contacts have been pressure tested to 10,000 psi, including cycling, with no degradation in performance.

OPTI-CON SERIES

PART NUMBER SYSTEM

EXAMPLE:

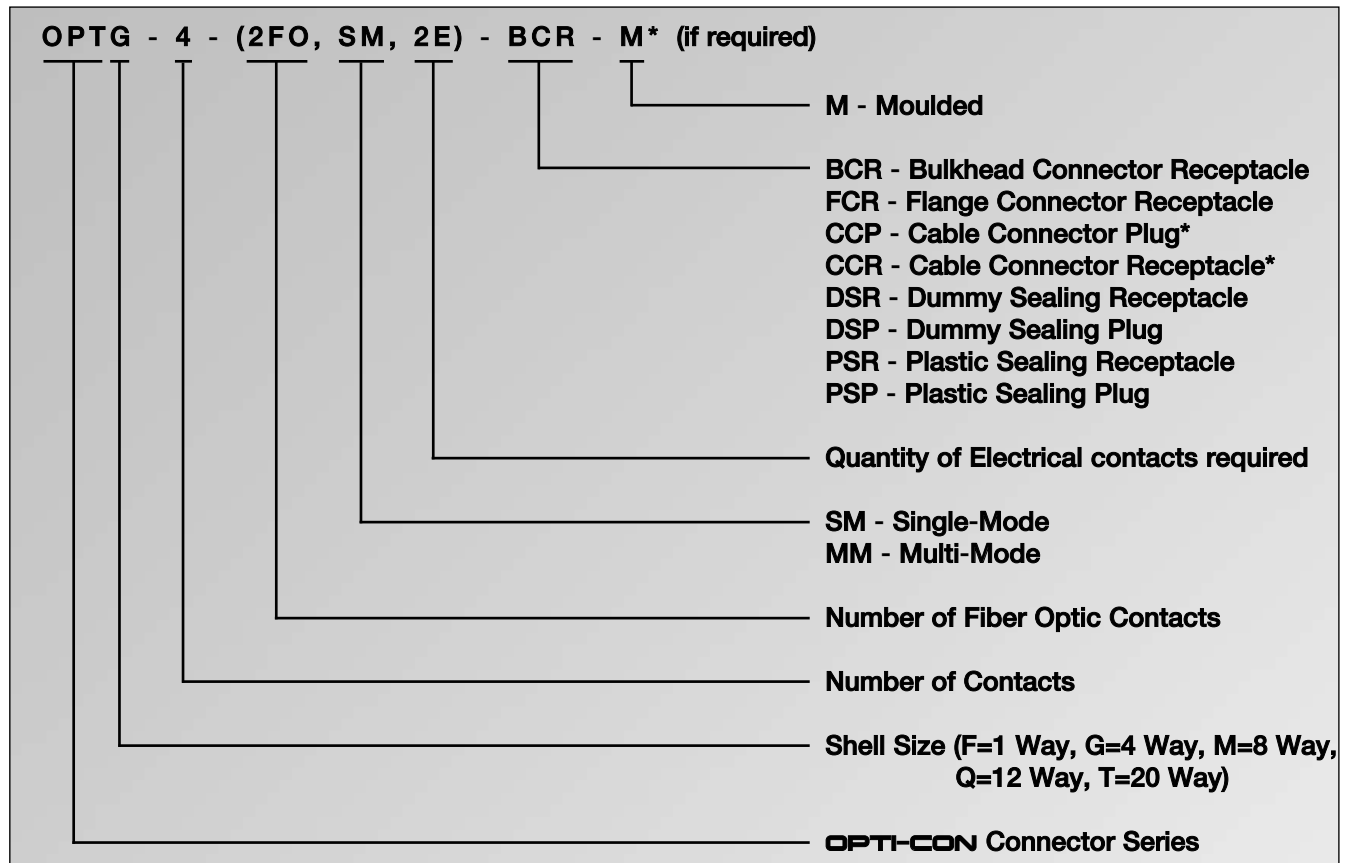

The above example would be the part number required to order a 4 way **OPTI-CON** connector. It would be a "G" size, would have 2 optical contacts (SM or MM to be specified), it would have 2 electrical contacts and would be a bulkhead receptacle shell style.

Oil filled hoses CCP and CCR connectors will be supplied as standard. If molded versions are required "-M" must be added to the end of the part number and a sample of cable supplied for test purposes.

Where ST or other style of connectors are required to be attached onto the BCR or FCR tails the style required and the length would need to be specified and would be priced accordingly.

Standard shell material is 316L Stainless Steel with NES833 engaging nut although other materials are available upon request. Preferred material should be specified at time of enquiry.

GENERAL INFORMATION

COMPONENT	MATERIAL
BULKHEAD BODY (BCR/FCR)	316L SS
CCP BODY	316L SS with Aluminum Bronze engaging nut per NES 833
CCR BODY	316L SS
ELECTRICAL CONTACTS	Aluminum Bronze per NES 833 GRE overmolded contact size 20 AWG
OPTICAL CONTACTS	Single or multi-mode with insertion losses of <0.5dB typically <0.3dB
O-RING	Nitrile (formerly known as Buna N)

CATEGORY	VALUE
MATED PRESSURE	7,500 psi (5,200m water depth)
VOLTAGE RATING	600 VDC @ 4 amps
TEMPERATURE RATING	-50C to +70C (-58F to 158F)
TYPICAL OPTICAL RETURN LOSS	<-50dB @1310 and 1550nm using single-mode fiber
LENGTH	Upto 30m maximum hose length at additional cost

* Standard supply is hose, however if cable is required please supply sample or specification.

DIMENSION DETAILS

OPTI-CON SERIES OPT-BCR

OPTI-CON Bulkhead Connector Receptacle
Mates with OPT-CCP
Dummy Connector: OPT-DSP

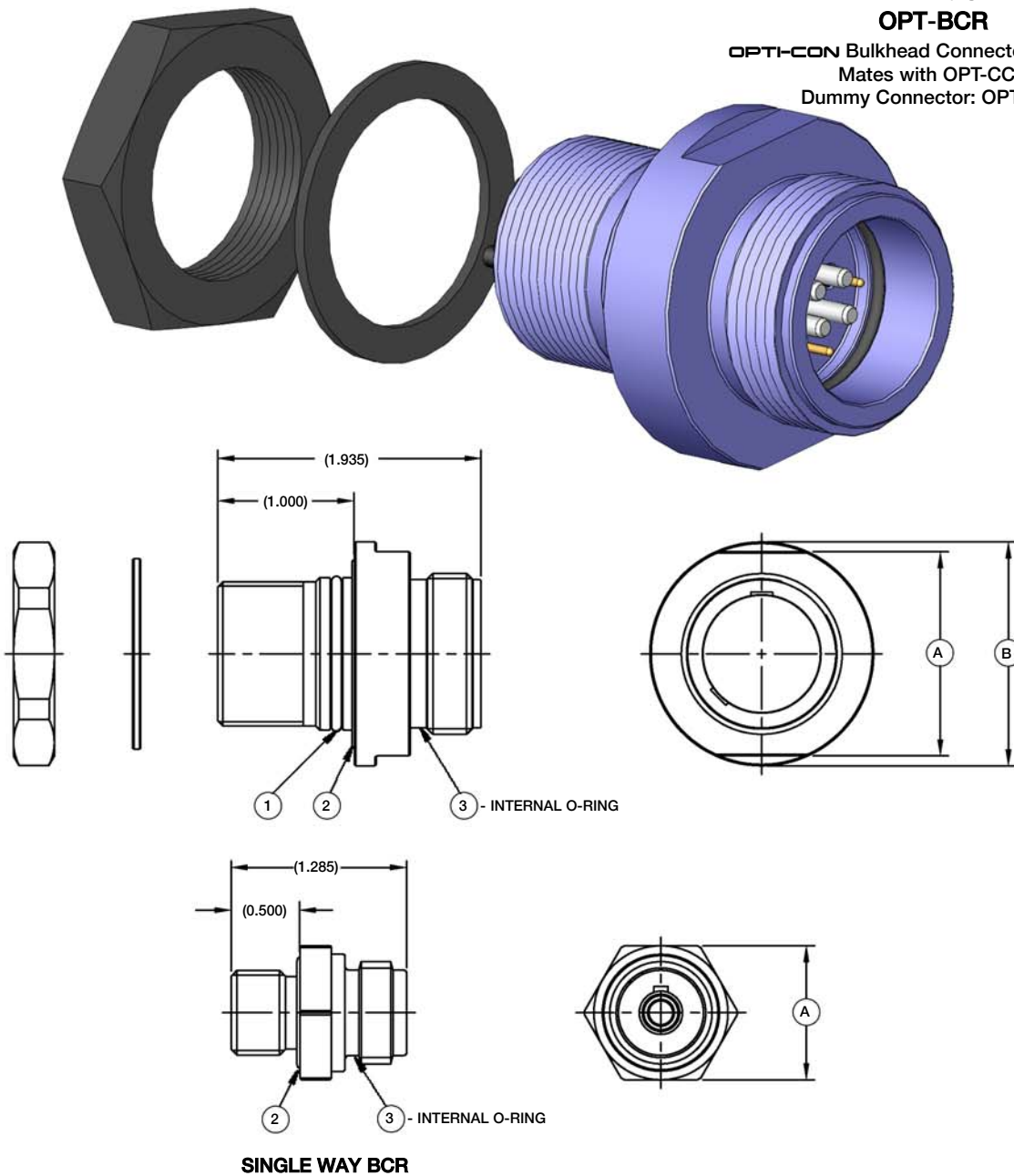

CONNECTOR	A - FLATS (INCHES)	B - Ø (INCHES)	1 - O-RING	2 - O-RING	3 - O-RING (INTERNAL)
OPT-F-BCR-SINGLE-WAY	0.980	N/A	N/A	017	011
OPT-G-4-BCR	1.25	1.400	018	022	016
OPT-M-8-BCR	1.50	1.645	022	026	020
OPT-Q-12-BCR	2.00	2.145	029	031	028
OPT-T-20-BCR	2.25	2.520	032	034	031

DIMENSION DETAILS

OPTI-CON SERIES OPT-FCR

OPTI-CON Flange Connector Receptacle
Mates with OPT-CCP
Dummy Connector: OPT-DSP

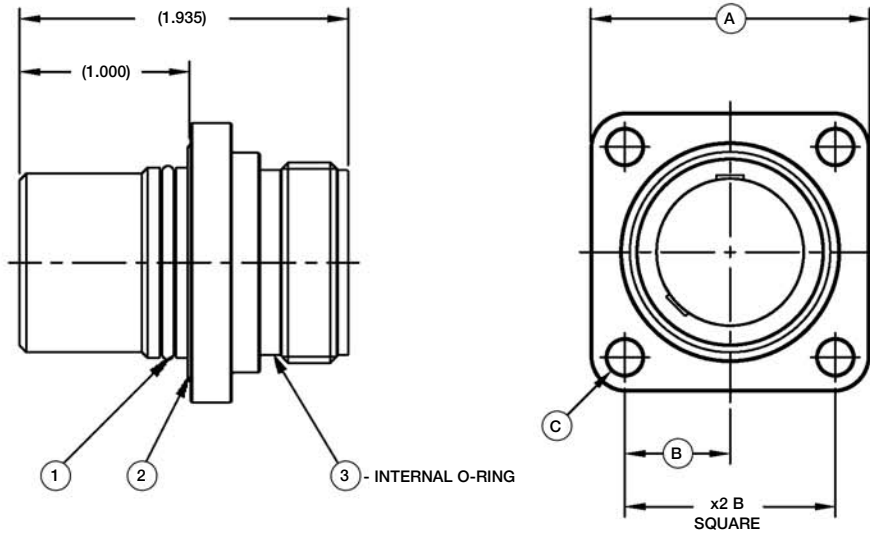
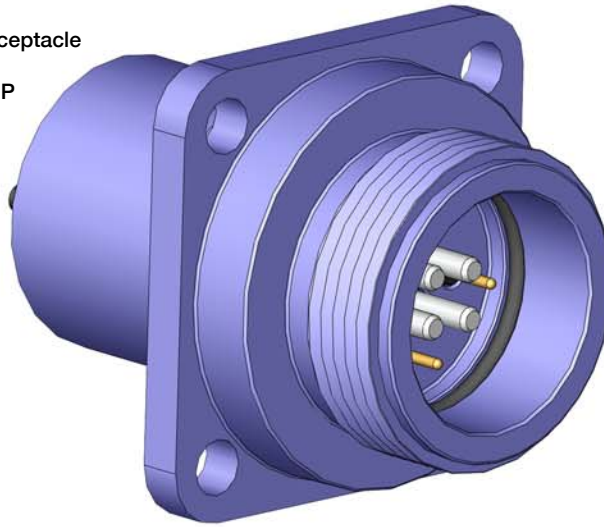

CONNECTOR	A - SQUARE (INCHES)	B - (INCHES)	C - Ø (INCHES)	1 - O-RING	2 - O-RING	3 - O-RING (INTERNAL)
OPT-F-FCR-SINGLE-WAY	1.180	0.425	0.167	012	017	011
OPT-G-4-FCR	1.400	0.540	0.167	018	022	016
OPT-M-8-FCR	1.645	0.620	0.206	022	026	020
OPT-Q-12-FCR	2.145	0.825	0.245	029	031	028
OPT-T-20-FCR	2.520	1.000	0.245	032	034	031

DIMENSION DETAILS

OPTI-CON SERIES
OPT-CCR (HOSE SHOWN)
 OPTI-CON Cable Connector Receptacle
 Mates with OPT-CCP
 Dummy Connector: OPT-DSP

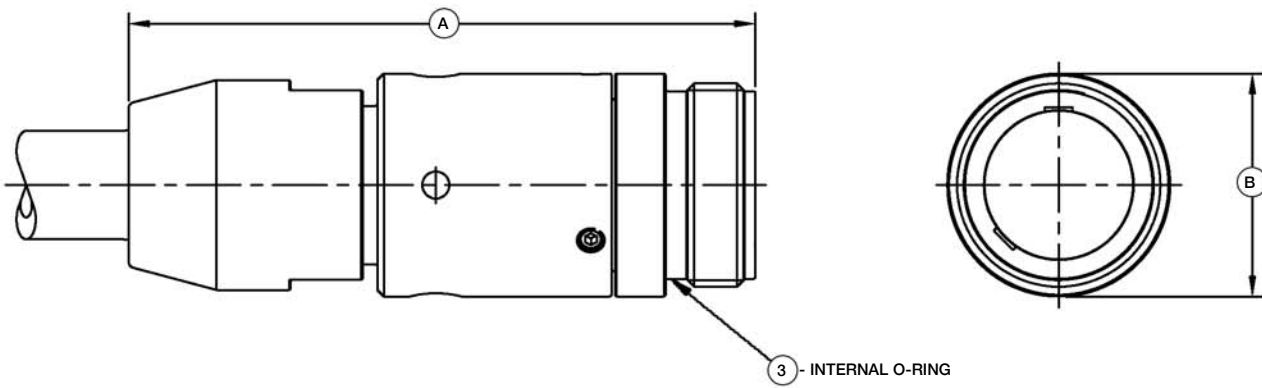
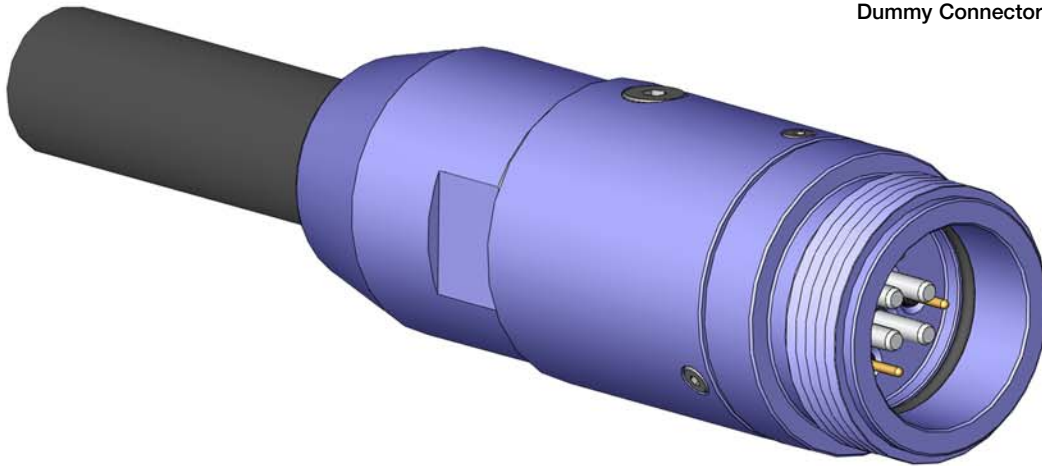

CONNECTOR	A - (INCHES)*	B - Ø (INCHES)	3 - O-RING (INTERNAL)
OPT-F-CCR-SINGLE-WAY	3.16	0.860	011
OPT-G-4-CCR	3.12	1.050	017
OPT-M-8-CCR	3.64	1.295	021
OPT-Q-12-CCR	4.65	1.795	517
OPT-T-20-CCR	4.83	2.170	031

* Length is longer for molded versions. Please contact SEA CON® for further details.

DIMENSION DETAILS

OPTI-CON SERIES OPT-CCP (HOSE SHOWN)

OPTI-CON Cable Connector Plug
Mates with OPT-BCR
Dummy Connector: OPT-DSR

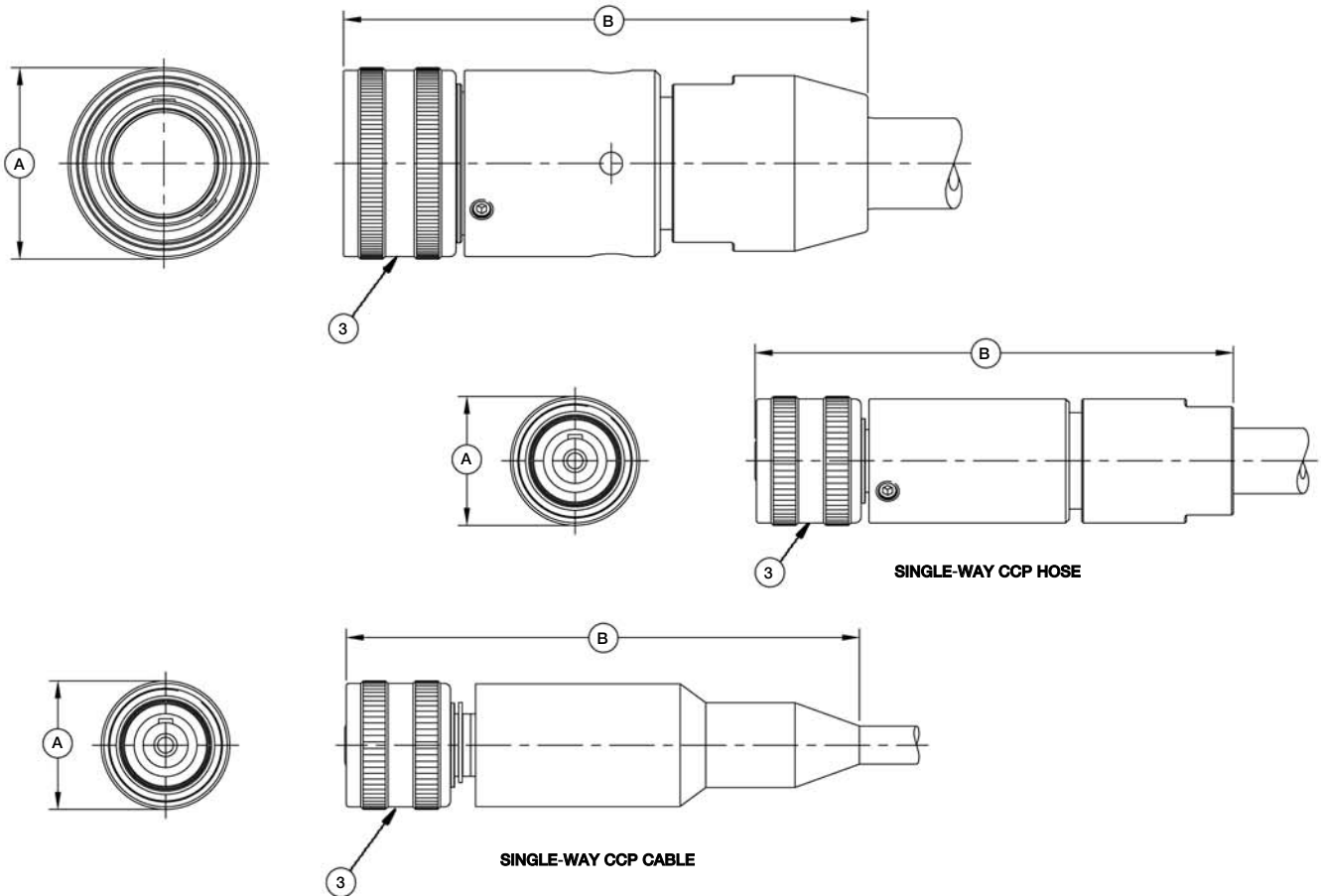
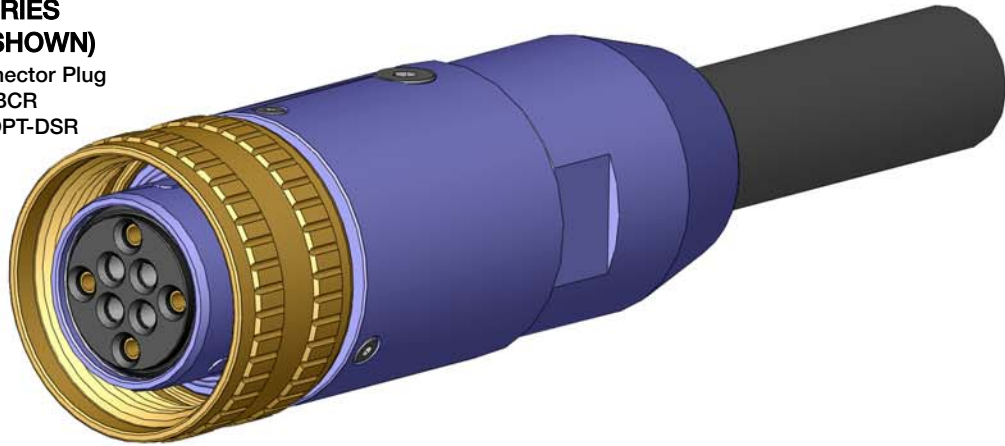

CONNECTOR	A - Ø (INCHES)	B - LENGTH (INCHES)*	3 - O-RING (INTERNAL)
OPT-F-CCP CABLE SINGLE-WAY	0.895	3.60	013
OPT-F-CCP HOSE SINGLE-WAY	0.895	3.32	013
OPT-G-4-CCP-HOSE	1.085	3.13	017
OPT-M-8-CCP-HOSE	1.330	3.64	021
OPT-Q-12-CCP-HOSE	1.830	4.66	517
OPT-T-20-CCP-HOSE	2.205	4.84	031

* Length is longer for molded versions. Please contact SEA CON® for further details.

DIMENSION DETAILS

OPTI-CON SERIES
OPT-PSP (DUST/SHIPPING CAPS)
 OPTI-CON Plastic Sealing Plug
 Mates with OPT-BCR/FCR/CCR

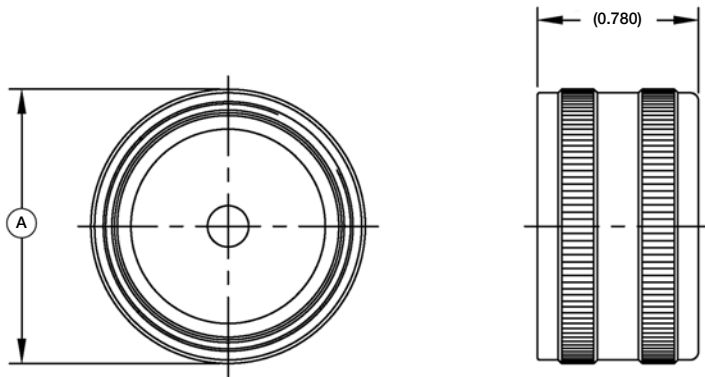

CONNECTOR	A - Ø (INCHES)
OPT-F-PSP/PSR SINGLE-WAY	0.900
OPT-G-4-PSP/PSR	1.085
OPT-M-8-PSP/PSR	1.330
OPT-Q-12PSP/PSR	1.830
OPT-T-20-PSP/PSR	2.205

OPTI-CON SERIES
OPT-PSR (DUST/SHIPPING CAPS)
 OPTI-CON Plastic Sealing Receptacle
 Mates with OPT-CCP

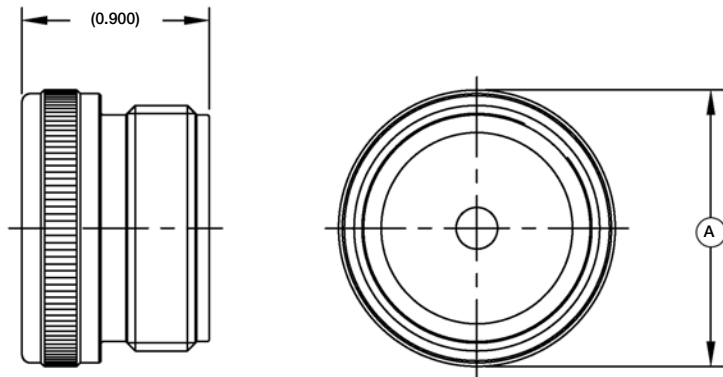

DIMENSION DETAILS

OPTI-CON SERIES OPT-DSP (FULL DEPTH SEALING CAPS)

OPTI-CON Dummy Sealing Plug
Mates with OPT-BCR/FCR/CCR

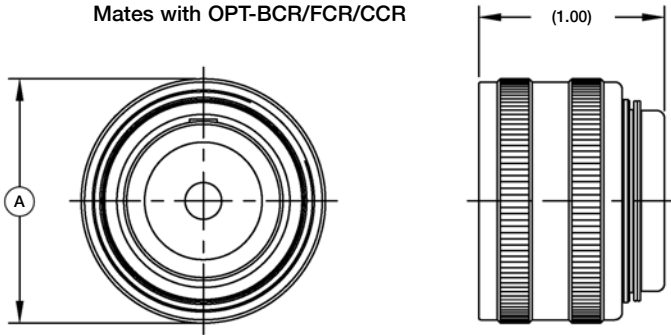

OPTI-CON SERIES OPT-DSP (FULL DEPTH SEALING CAPS) SINGLE-WAY

OPTI-CON Dummy Sealing Plug
Mates with OPT-BCR/FCR/CCR

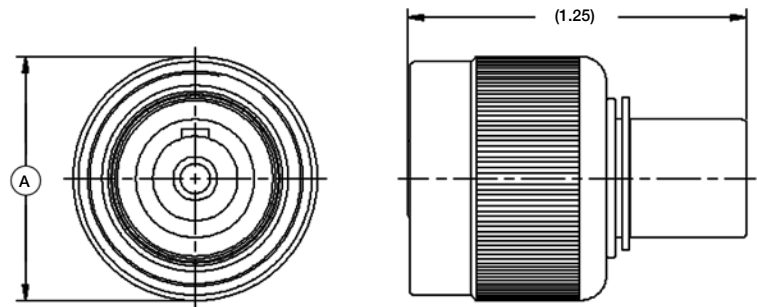

CONNECTOR	A - Ø (INCHES)
OPT-F-DSP-SINGLE-WAY	0.900
OPT-G-4-DSP	1.085
OPT-M-8-DSP	1.330
OPT-Q-12-DSP	1.830
OPT-T-20-DSP	2.205

OPTI-CON SERIES OPT-DSR (FULL DEPTH SEALING CAPS)

OPTI-CON Dummy Sealing Receptacle
Mates with OPT-CCP

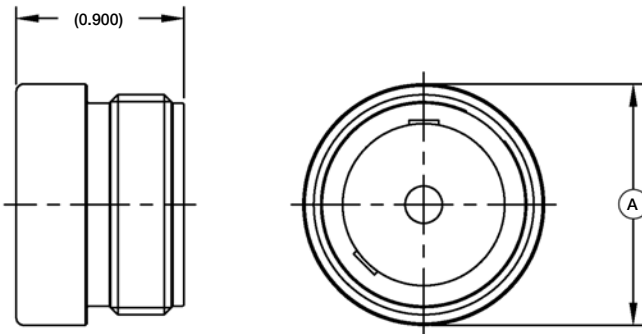

OPTI-CON SERIES OPT-DSR (FULL DEPTH SEALING CAPS) SINGLE-WAY

OPTI-CON Dummy Sealing Receptacle
Mates with OPT-CCP

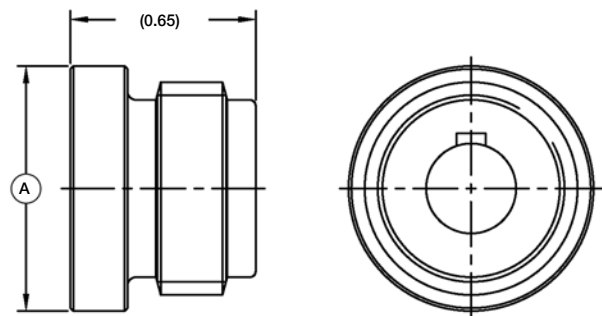

CONNECTOR	A - Ø (INCHES)
OPT-F-DSR-SINGLE-WAY	0.860
OPT-G-4-DSR	1.050
OPT-M-8-DSR	1.295
OPT-Q-12-DSR	1.795
OPT-T-20-DSR	2.170

INTERFACE DETAILS

OPTI-CON SERIES OPT-BCR SINGLE-WAY

OPTI-CON Bulkhead Connector Receptacle
Mates with OPT-CCP
INTERFACE THREADED MOUNTING OPTION

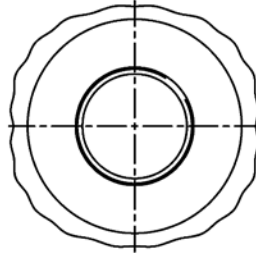
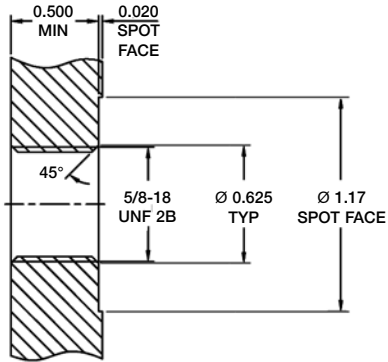

**OPTI-CON SERIES
OPT-BCR SINGLE-WAY**
OPTI-CON Bulkhead Connector Receptacle
Mates with CCP
THROUGH BORE MOUNTING OPTION

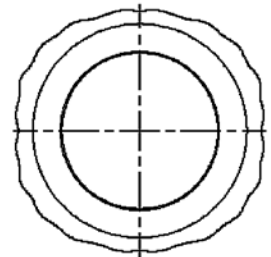
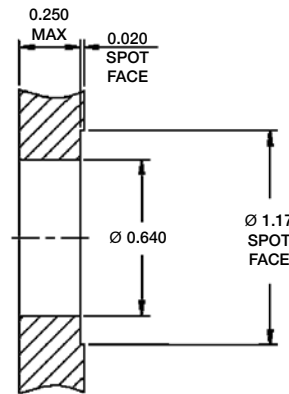

OPTI-CON SERIES OPT-FCR

OPTI-CON Flange Connector Receptacle
Mates with OPT-CCP
INTERFACE MOUNTING OPTION

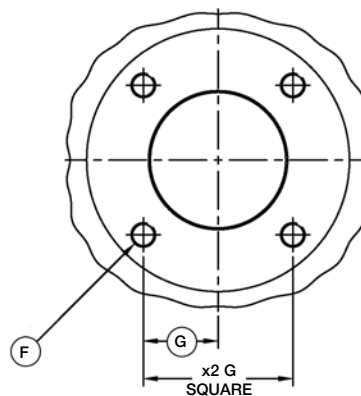
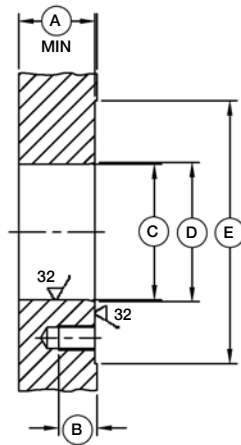

FCR INTERFACE THREADED MOUNTING INFORMATION

CONNECTOR	A - (INCHES)	B - (INCHES)	C - Ø (INCHES)	D - Ø (INCHES)	E - SPOT FACE Ø (INCHES)	F - THREAD	G - (INCHES)
OPT-G-4-FCR	0.480	0.30	0.868 0.870	0.900	1.875	M4	0.540
OPT-M-8-FCR	0.630	0.30	1.123 1.125	1.154	2.180	M5	0.620
OPT-Q-12-FCR	0.830	0.48	1.623 1.625	1.654	2.860	M6	0.825
OPT-T-20-FCR	0.830	0.48	1.998 2.000	2.029	3.380	M6	1.000

INTERFACE DETAILS

OPTI-CON SERIES OPT-BCR

OPTI-CON Bulkhead Connector Receptacle
Mates with OPT-CCP
THROUGH BORE MOUNTING OPTION
UTILIZING BACK NUT AND WASHER

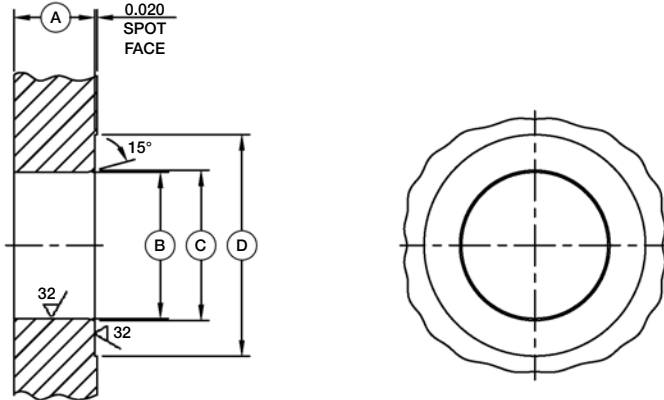

BCR THROUGH BORE MOUNTING INFORMATION

CONNECTOR	A - (INCHES)	B - \varnothing (INCHES)	C - \varnothing (INCHES)	D - \varnothing (INCHES)
OPT-G-4-BCR	0.710 0.400	0.868 0.870	0.900	1.500
OPT-M-8-BCR	0.620 0.400	1.123 1.125	1.154	1.700
OPT-Q-12-BCR	0.620 0.400	1.623 1.625	1.654	2.200
OPT-T-20-BCR	0.620 0.400	1.998 2.000	2.029	2.575

OPTI-CON SERIES OPT-BCR

OPTI-CON Bulkhead Connector Receptacle
Mates with OPT-CCP
INTERFACE THREADED MOUNTING OPTION

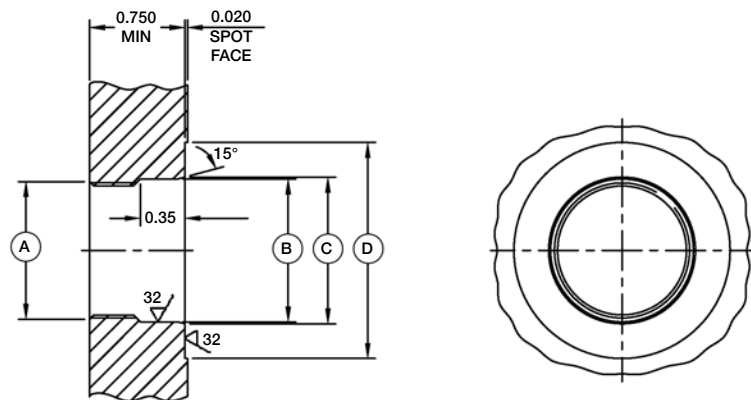

BCR INTERFACE MOUNTING INFORMATION

CONNECTOR	A - THREAD	B - \varnothing (INCHES)	C - \varnothing (INCHES)	D - \varnothing (INCHES)
OPT-G-4-BCR	13/16-20 UNEF 2B	0.868 0.870	0.900	1.500
OPT-M-8-BCR	1 1/16-20 UN 2B	1.123 1.125	1.154	1.700
OPT-Q-12-BCR	1 9/16-20 UN 2B	1.623 1.625	1.654	2.200
OPT-T-20-BCR	1 15/16-20 UN 2B	1.998 2.000	2.029	2.575

CONTACT CONFIGURATIONS

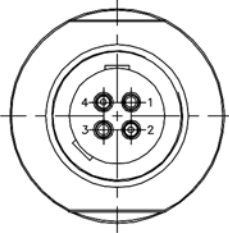
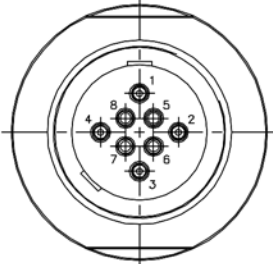
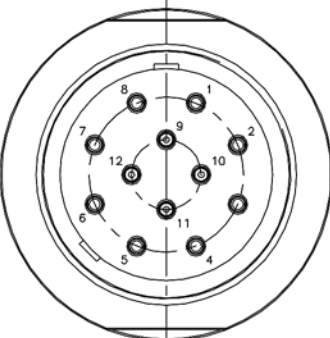
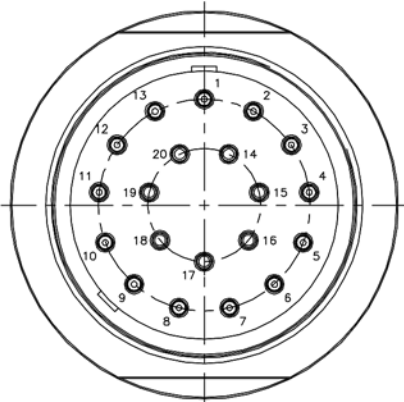
SIZE	OPTI-CON SERIES BCR/FCR/CCR CONTACT CONFIGURATIONS AVAILABLE (MALE FACE VIEW ONLY)*
1	 <p data-bbox="305 394 370 415">OPT-F-1</p>
4	 <p data-bbox="321 667 386 688">OPT-G-4</p>
8	 <p data-bbox="345 993 410 1014">OPT-M-8</p>
12	 <p data-bbox="362 1396 443 1417">OPT-Q-12</p>
20	 <p data-bbox="402 1848 483 1869">OPT-T-20</p>

* For female CCP face view contact configurations available please contact SEA CON®.

HANDLING PROCEDURES AND SPECIAL CAPABILITIES



SEACON (europe) LTD

Seacon House, Hewett Road,
Gapton Hall Industrial Estate,
Great Yarmouth, Norfolk, NR31 0RB, UK.
TEL: +44 (0) 1493-652733
FAX: +44 (0) 1493-652840
E-Mail: sales@seaconeurope.com
Website: www.seaconeurope.com



SEA CON®

1700 Gillespie Way,
El Cajon, California 92020, USA.
TEL: +1 (619) 562-7071
FAX: +1 (619) 562-9706
E-Mail: seacon@seacon-usa.com
Website: www.seaconworldwide.com



SEA CON US GULF AREA SALES OFFICE

21925 Franz Road, Suite 401,
Katy, Texas 77449, USA.
TEL: +1 (281) 599-3509
FAX: +1 (281) 599-3517
E-Mail: gulfcoastsales@seaconbrantner.com
Website: www.seaconworldwide.com



SEA CON US EAST COAST SALES OFFICE

50 Airport Road,
Westerly, RI 02891, USA.
TEL: +1 (401) 348-0155
FAX: +1 (401) 348-0227
E-Mail: eastcoastsales@seaconbrantner.com
Website: www.seaconworldwide.com



SEA CON FLORIDA SALES OFFICE

Building B, Suite 22,
3959 South Nova Road,
Port Orange,
Florida 32127, USA.
TEL: +1 (281) 802-5504
E-Mail: steven.thumbeck@seacon-ap.com



SEACON ADVANCED PRODUCTS, LLC

1321 Nelius Road, P.O. Box 767,
Bellville, Texas 77418, USA.
TEL: +1 (979) 865-8846
FAX: +1 (979) 865-8859
E-Mail: sales@seacon-ap.com
Website: www.seacon-ap.com



SEACON BRAZIL

Rua Conde de Bonfim 120 sala 212,
Tijuca, Rio de Janeiro,
Brazil, CEP: 20520-053.
TEL: +55 (21) 8849-3336
E-Mail: renata@seacon-ap.com



SEA CON GLOBAL PRODUCTION

Callejon Terrazos #8, Local 2-C,
Las Brisas 1ra. Seccion,
Tijuana, B.C., Mexico C.P. 22610.
TEL: +52 (664) 626-2726
FAX: +52 (664) 686-8922
E-Mail: sales@seaconglobal.com
Website: www.seaconglobal.com
Dial from U.S.A. TEL: +1 (619) 308-7901
TOLL FREE: (888) 562-7072
FAX: +1 (619) 308-7900



SEACON PHOENIX, LLC.

15 Gray Lane, Suite 108,
Hopkinton Industrial Park,
Ashaway, RI 02804, USA.
TEL: +1 (401) 637-4952
FAX: +1 (401) 637-4953
E-Mail: sales@seaconphoenixllc.com
Website: www.seaconphoenixllc.com

Even though these procedures appear simple, only qualified technicians should perform the installation and maintenance.

INSTALLATION PROCEDURES

Torque values referenced assume installation into dry metal threads. Bulkhead connector receptacle (BCR) o-ring should be lubricated with an appropriate silicone grease before installing. This lubricant should be applied to form an adequate film. Excessive lubrication is detrimental to the operation of the connector. Care must be taken to ensure no grease or dirt is present on the face of the fiber optic contact. Cleaning of the contact is recommended using only suitable products. CCP o-ring should be greased as above with the same care being taken.

CARE AND MAINTENANCE

Once mated the connector requires no maintenance. When stored all fiber contacts should be protected with suitable dust caps.

CABLE AND CONTINUITY PRESERVATION

Avoid sharp bends in both the hose assembly and the tail ends of the BCR so that breakage of the fiber does not occur.

SPECIAL ASSEMBLIES

SEACON (europe) Ltd maintains all facilities necessary to furnish complete underwater and environmental electrical connector/cable systems, including Research and Development, Engineering, Manufacturing, Quality Control and Pressure Testing. As well as supplying our standard 'off-the-shelf' items, we have the capability to design and manufacture SPECIAL CUSTOMISED CONNECTORS AND CABLE ASSEMBLIES to suit your individual needs.

All reasonable efforts have been taken to ensure that the information contained herein is accurate at the date of publication, but no representation or warranty as to the accuracy or completeness of such information is intended or to be implied by its inclusion herein. Any and all representations and warranties pertaining to the information and products referred to herein shall be set forth in SEA CON® standard sales order form. In addition, SEA CON® reserves the right to make changes to the contents hereof without notice, therefore it is suggested that at the time of enquiry, the appropriate sales office or factory be contacted directly for verification of published specifications and products availability.

© 2011 SEACON (europe) LTD

ALL RIGHTS RESERVED



REV III