

The logo for SEACON, with each letter 'S', 'E', 'A', 'C', 'O', 'N' in a white, bold, sans-serif font inside a blue square. A registered trademark symbol (®) is located to the right of the 'N' square.

SEACON®

UNDERWATER ELECTRICAL AND FIBER OPTIC CONNECTORS

A collection of various underwater electrical connectors, including multi-pin circular connectors and a fiber optic connector, arranged on a blue background with water droplets. The connectors are shown in various orientations, some showing their internal contacts and others showing their external housing.

**GLASS REINFORCED
EPOXY (GRE)**

UNDERWATER ELECTRICAL DRY-MATE CONNECTORS

SECTION **PAGE**

GLASS REINFORCED EPOXY (GRE) SERIES

Introduction GRE 2

Availability GRE 2

Applications GRE 2

Special Assemblies GRE 2

Part Number System GRE 2

General Information GRE 2

Visual Index GRE 3-5

Dimension Details:

 XSEE-BCR GRE 6

 XSEE-CCR GRE 6

 XSEE-CCP GRE 7

 MSXEE-BCR GRE 8

 XSJ-BCR GRE 8

 XSJ-CCR GRE 9

 XSJ-CCP GRE 9

 MSXJ-BCR GRE 10

 XSJJ-BCR GRE 10

 XSJJ-CCR GRE 11

 XSJJ-CCP GRE 11

 MSXJJ-BCR GRE 12

 XSL-BCR GRE 12

 XSL-CCR GRE 13

 XSL-CCP GRE 13

 XSL-CCP-FI GRE 14

 XSL-CCR-FI GRE 14

 MSXL-BCR GRE 15

 XSL-BCR-PBOF GRE 15

 XSL-CCP-PBOF GRE 16

 XSM-BCR GRE 16

 XSM-CCR GRE 17

 XSM-CCP GRE 17

 XSM-CCP-FI GRE 18

 XSM-CCR-FI GRE 18

 MSXM-BCR GRE 19

Contact Configurations GRE 20

GRE Rubber Molded Mates GRE 21

INTRODUCTION

Our standard Glass Reinforced Epoxy (XS) line of connectors consist of gold plated contacts molded in Glass Reinforced Epoxy. SEA CON® has been manufacturing these connectors for many years and continues to expand this product line with even better and more reliable designs.

AVAILABILITY

These keyed connectors are available in a variety of sizes with contact patterns up to 36 and pressure ratings up to 20,000 psi (approximately 45,000 ft/13,700m). Many of these connectors are available with a Stainless Steel housed bulkhead connector for increased ruggedness which is completely interchangeable with the Glass Reinforced Epoxy version. Field installable, Pressure Balanced Oil Filled (PBOF) and optical versions are also available.

APPLICATIONS

This series of connectors has been used on many diverse applications such as deep ocean and ship sub-surface electronics and is also suitable for a variety of other uses including ROV's, underwater cameras and lights, diver communication systems, mine counter measure assemblies and survey equipment.

SPECIAL ASSEMBLIES

SEA CON® maintains all facilities necessary to furnish complete underwater and environmental electrical connector/cable systems, including Research and Development, Engineering, Manufacturing, Quality Control and Pressure Testing.

As well as supplying our standard 'off-the-shelf' items, we have the capability to design and manufacture **SPECIAL CUSTOMIZED CONNECTORS AND CABLE ASSEMBLIES** to suit your individual needs.

SEA CON® also prides itself with the ability to perform stringent quality conformance testing procedures which are in accordance with the MIL-SPEC programs.

Please contact SEA CON® for further information.

PART NUMBER SYSTEM - EXAMPLE

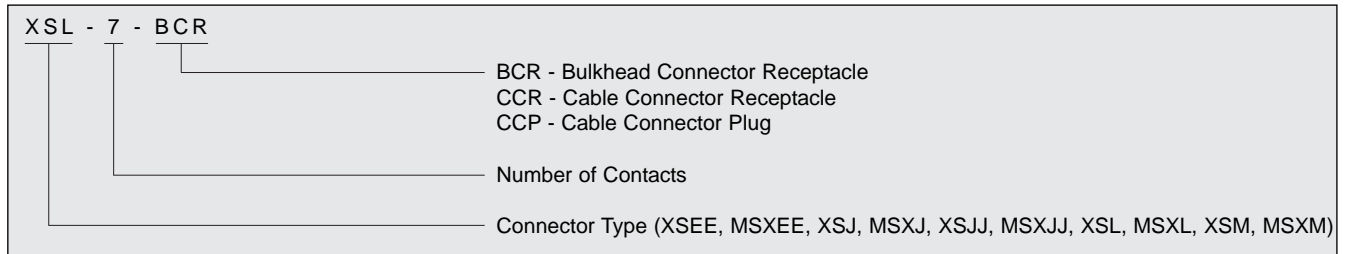

GENERAL INFORMATION

COMPONENT	MATERIAL
XS-BCR/CCR/CCP BODY	Glass Reinforced Epoxy (GRE) B/A XS-2748
MSX-BCR BODY	316 Stainless Steel
CONTACT INSERTS	Glass Reinforced Epoxy (GRE) B/A XS-2748
ELECTRICAL CONTACTS	Copper Alloy and Gold plated per MIL-G-45204
O-RING	Nitrile (formerly known as Buna N)

CATEGORY	VALUE
MATED PRESSURE	Up to 20,000 psi mated
VOLTAGE RATING	Up to 2,800 VDC. Please see page 20 for specific ratings in this brochure.
CURRENT	Up to 200 amps

OPTIONS:

- Field Installable.
- Pressure Balanced Oil Filled (PBOF).
- Coax available.
- Optic version (please see separate Fiber Optic brochure).
- Cable termination additional.

NOTES:

- Connectors are designed for installation on one atmosphere vessels. Please contact SEA CON® for recommendations if using compensated vessels.
- Torque values shown in this brochure refers to installation into dry metal threads.

NON-METALLIC CONNECTOR SERIES

VISUAL INDEX

XSJJ SERIES SUPERCEDES THE XSJ SERIES

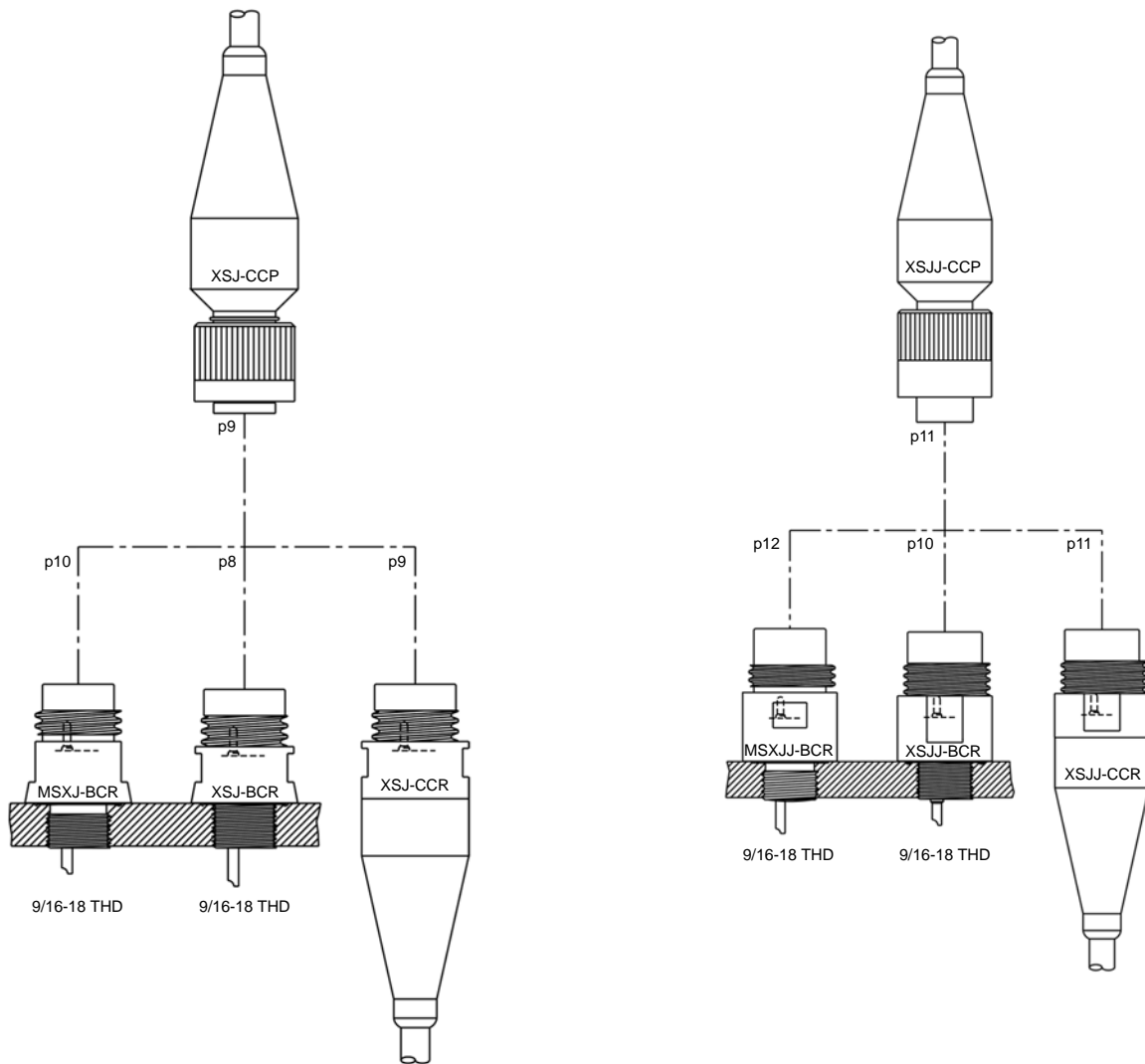

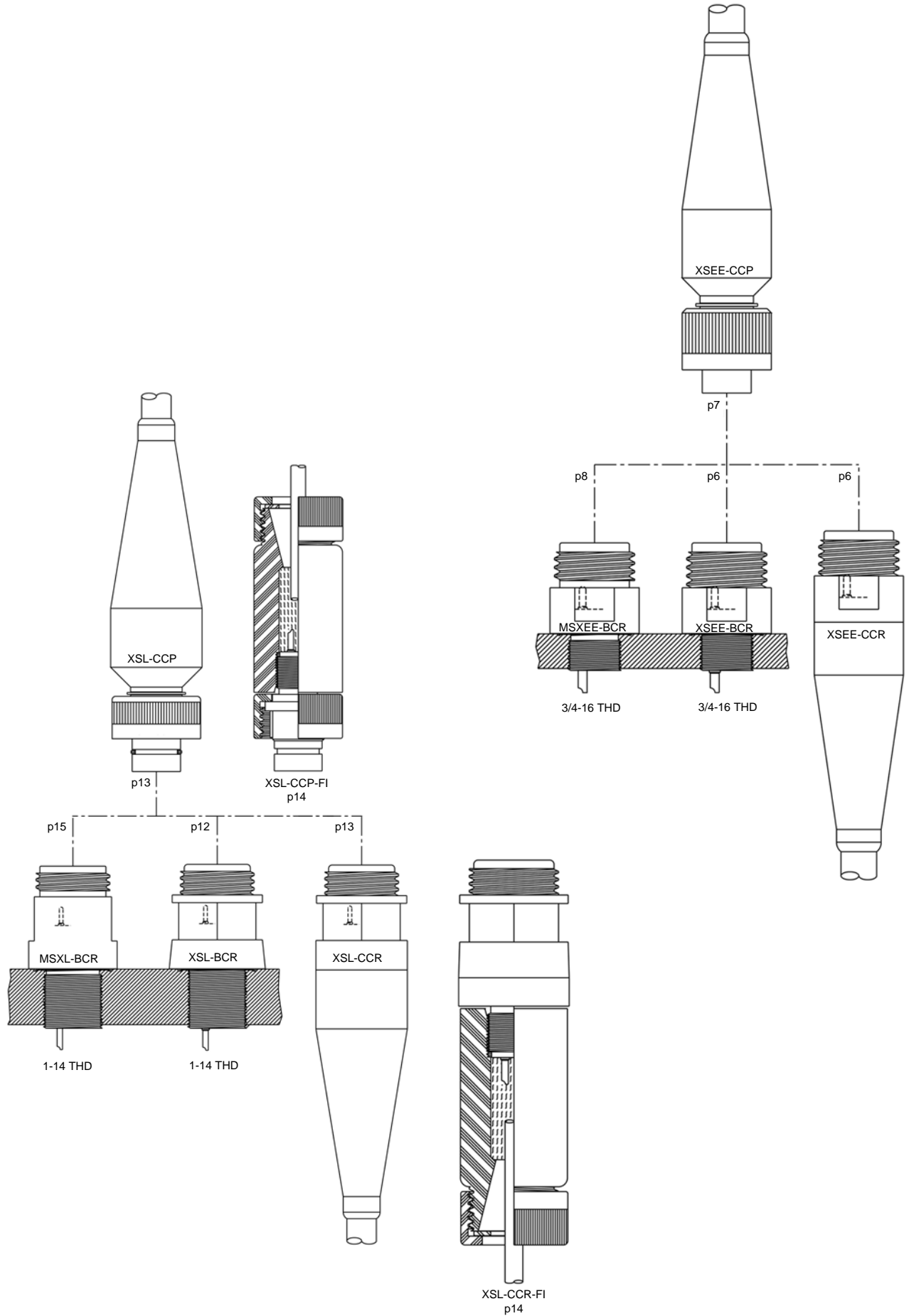

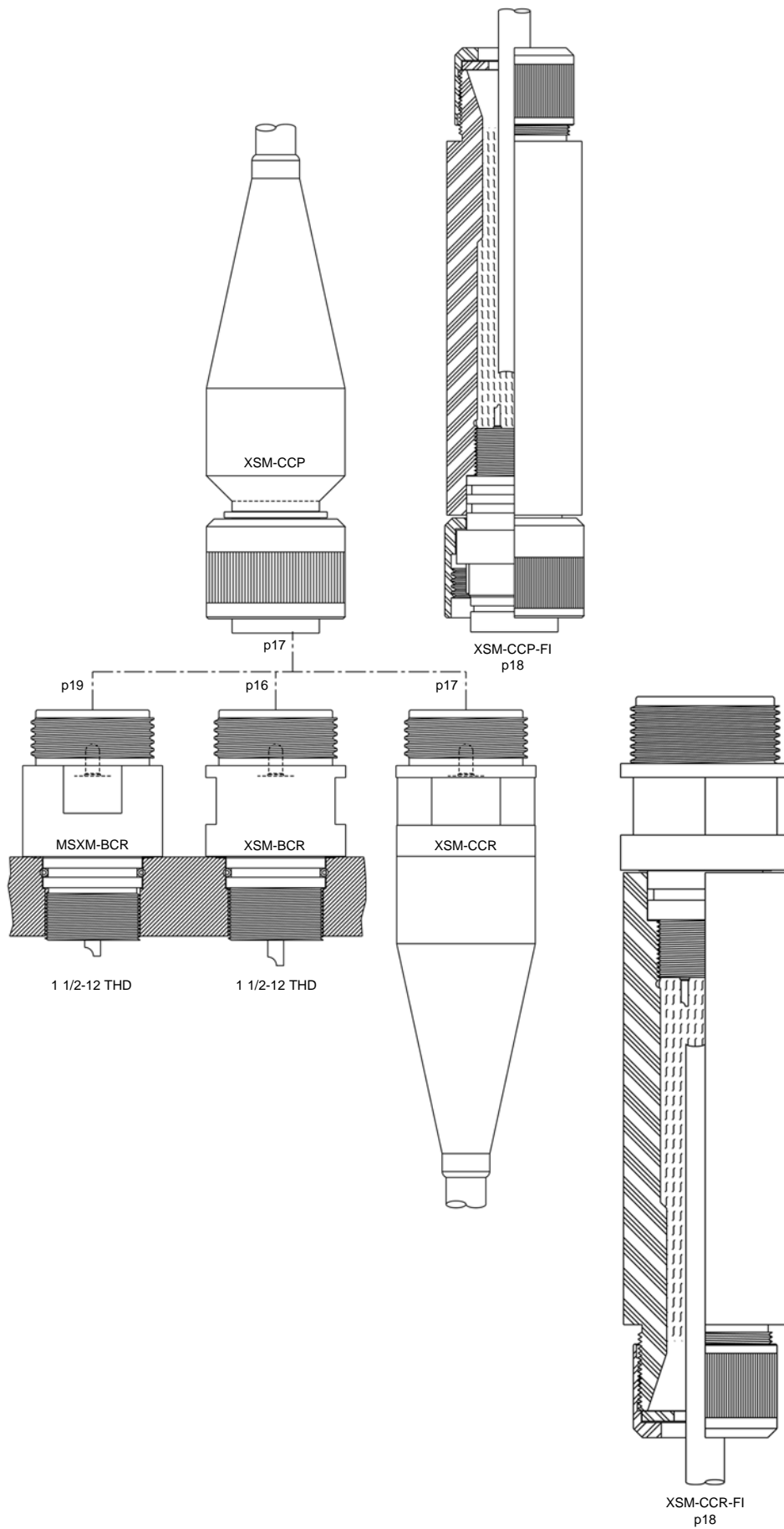

**GRE XSEE SERIES
XSEE-BCR**

GRE Bulkhead Connector Receptacle
Mates with XSEE-CCP
Dummy Connector: XSEE-DSP

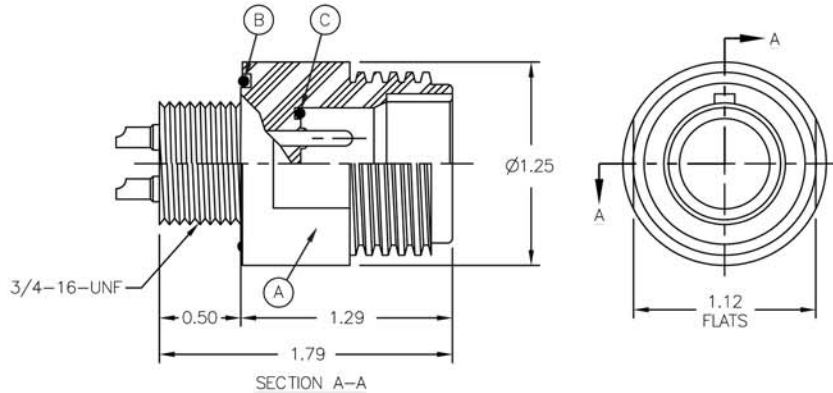

A - CONNECTOR BODY	B - O-RING	C - O-RING
XSEE-BCR	2-021	5-001

**GRE XSEE SERIES
XSEE-CCR**

GRE Cable Connector Receptacle
Mates with XSEE-CCP
Dummy Connector: XSEE-DSP

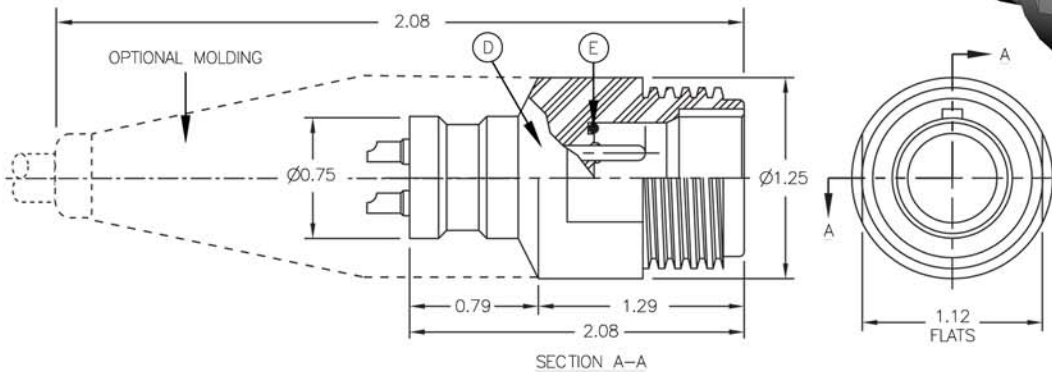

D - CONNECTOR BODY	E - O-RING
XSEE-CCR	5-001

NOTES:

- Body: Glass Reinforced Epoxy B/A XS-2748.
- Contacts: Copper Alloy and Gold plated per MIL-G-45204.
- O-ring: Nitrile (formerly known as Buna N).
- Specifications:
 - Pressure: Atmospheric to 10,000 psi mated.
 - Temperature Range: -57°C to +93°C (-70°F to +200°F).
 - Mounting Torque: 75 in-lbs in dry metal threads (XSEE-BCR).
 - Maximum Cable Diameter: 0.62 (XSEE-CCR).
- See page 20 for all contact configurations available.

OPTIONS:

- 18 inch Teflon® (Registered trademark for DuPont) pigtailed are an option as are customer specified tails (XSEE-BCR).
- Nut and washer set for Bulkhead Connector installation (XSEE-BCR).
- Open face pressure resistance.
- Cable and molding is optional at additional cost (XSEE-CCR).

GRE XSEE SERIES XSEE-CCP

GRE Cable Connector Plug
Mates with XSEE-BCR/CCR & MSXEE-BCR
Dummy Connector: XSEE-DSR

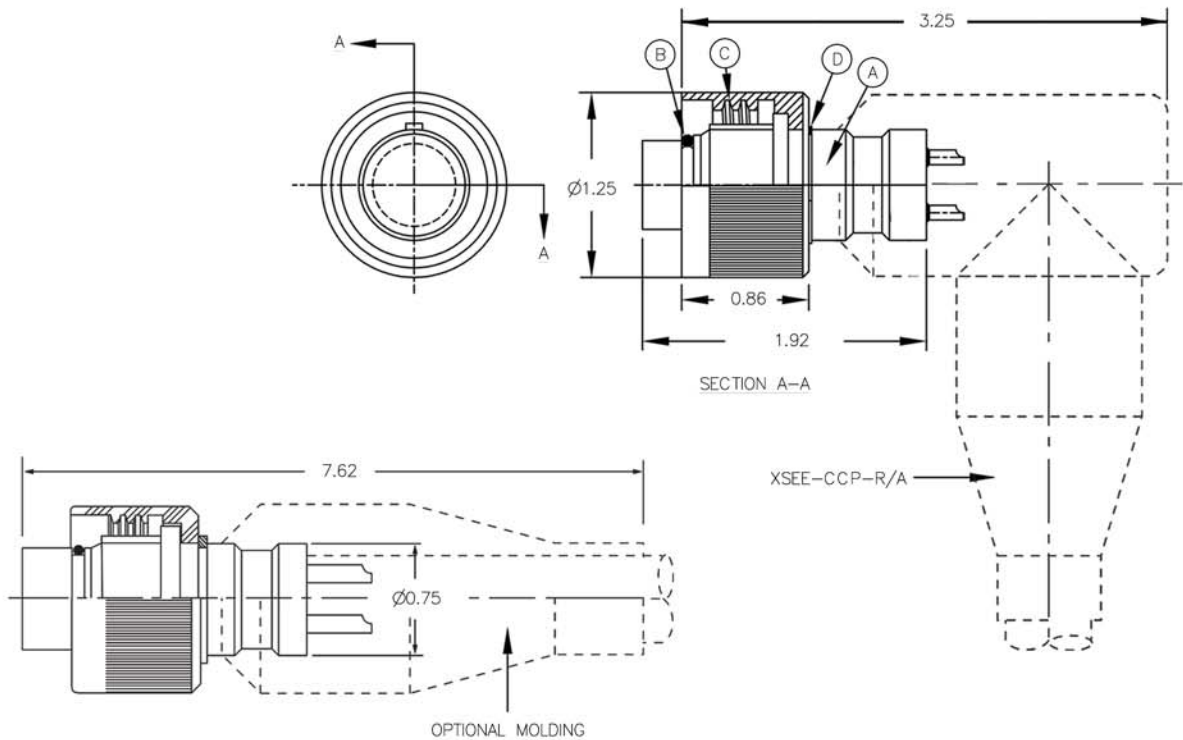

A - CONNECTOR BODY	B - O-RING	C	D - RETAINING RING
XSEE-CCP	2-015	ENGAGING NUT	5100-75

NOTES:

- Body: Glass Reinforced Epoxy B/A XS-2748.
- Contacts: Copper Alloy and Gold plated per MIL-G-45204.
- O-ring: Nitrile (formerly known as Buna N).
- Engaging Nut: Delrin® (DuPont trademark for Acetal Resin).
- Retaining Ring: Stainless Steel, PH 15-7 MO.
- Specifications:
 - Pressure: Atmospheric to 10,000 psi mated.
 - Temperature Range: -57°C to +93°C (-70°F to +200°F).
 - Maximum Cable Diameter: 1.000 for straight and 0.500 for right angle.
- See page 20 for all contact configurations available.

OPTIONS:

- Open face pressure resistance.
- Cable and molding is optional at additional cost.

GRE XSEE SERIES MSXEE-BCR

Stainless Steel Bulkhead Connector Receptacle
Mates with XSEE-CCP
Dummy Connector: XSEE-DSP

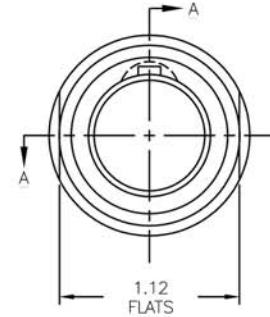
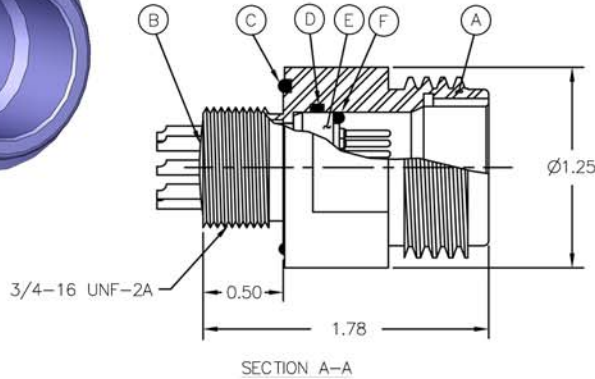
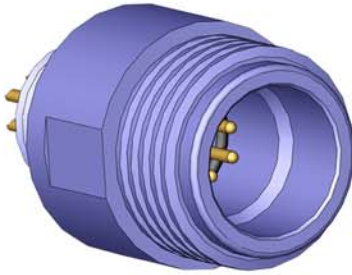

A - CONNECTOR SHELL	B	C - O-RING	D - O-RING	E	F - O-RING
MSXEE-CCP	POTTING	2-021	2-017	MSXEE-CIR	5-001

GRE XSJ SERIES * XSJ-BCR

GRE Bulkhead Connector Receptacle
Mates with XSJ-CCP
Dummy Connector: XSJ-DSP

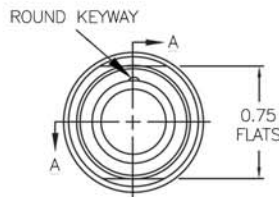
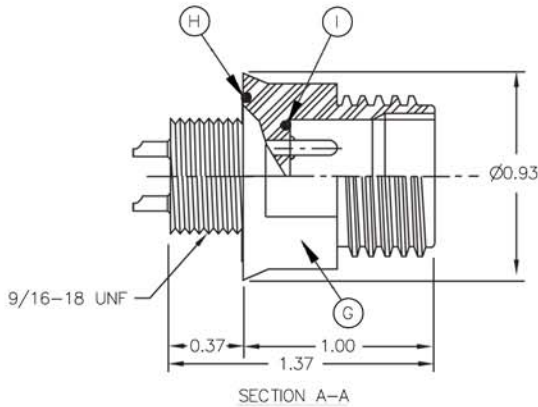

G - CONNECTOR BODY	H - O-RING	I - O-RING
XSJ-BCR	5-254	5-058

NOTES:

- * Whilst XSJ connectors are still available, they have been superseded by the XSJJ and we recommend the XSJJ for new applications.
- Shell: 316 Stainless Steel, passivated (MSXEE-BCR).
- Body: Glass Reinforced Epoxy B/A XS-2748 (XSJ-BCR).
- Contacts: Copper Alloy and Gold plated per MIL-G-45204.
- Back Potting: White Epoxy (MSXEE-BCR).
- O-ring: Nitrile (formerly known as Buna N).
- Specifications:
 - Pressure: Atmospheric to 10,000 psi mated.
 - Temperature Range: -57°C to +93°C (-70°F to +200°F).
 - Mounting Torque: 75 in-lbs in dry metal threads (MSXEE-BCR) / 20 in-lbs in dry metal threads (XSJ-BCR).
- See page 20 for all contact configurations available.

OPTIONS:

- 18 inch Teflon® (Registered trademark for DuPont) pigtailed are an option as are customer specified tails.
- Nut and washer set for Bulkhead Connector installation.
- Open face pressure resistance.

**GRE XSJ SERIES *
XSJ-CCR**

GRE Cable Connector Receptacle
Mates with XSJ-CCP
Dummy Connector: XSJ-DSP

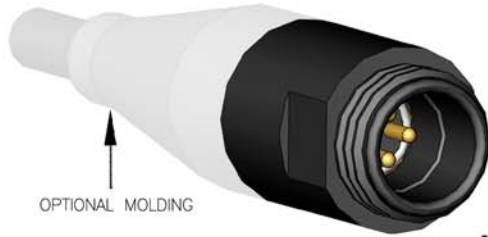

OPTIONAL MOLDING

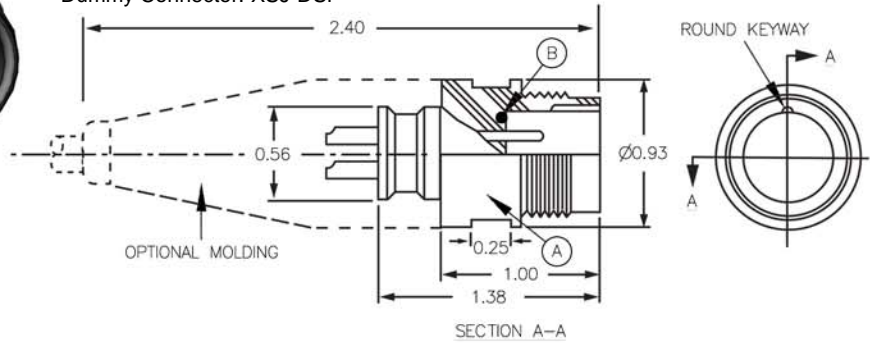

A - CONNECTOR BODY	B - O-RING
XSJ-CCR	5-058

**GRE XSJ SERIES *
XSJ-CCP**

GRE Cable Connector Plug
Mates with XSJ-BCR/CCR & MSXJ-BCR
Dummy Connector: XSJ-DSR

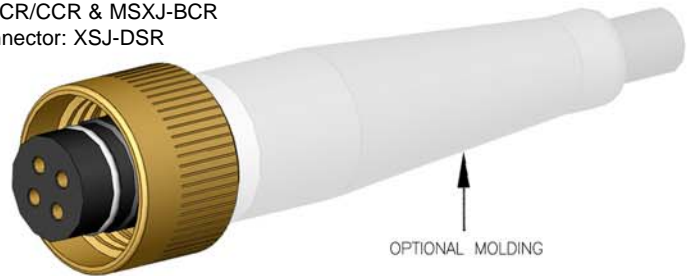

OPTIONAL MOLDING

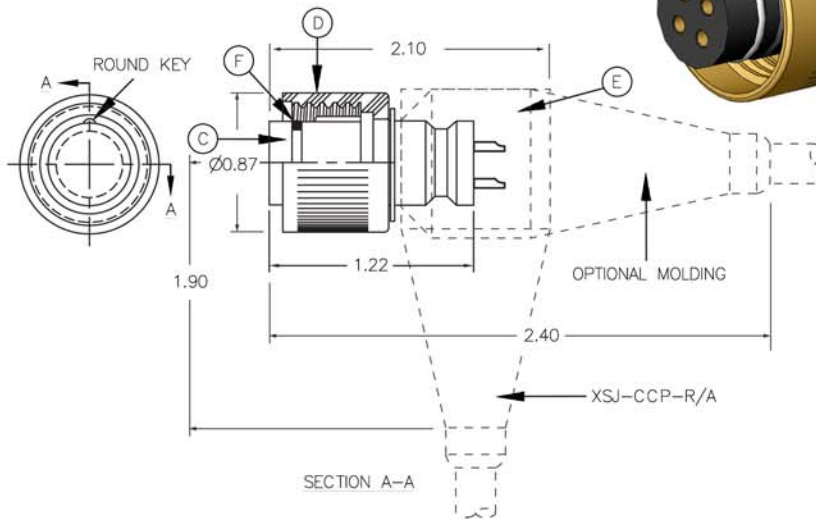

C - CONNECTOR BODY	D	E - MOLD	F - O-RING
XSJ-CCP	ENGAGING NUT	POLYURETHANE OR NEOPRENE	2-013

NOTES:

- * Whilst XSJ connectors are still available, they have been superseded by the XSJJ and we recommend the XSJJ for new applications.
- Body: Glass Reinforced Epoxy B/A XS-2748.
- Contacts: Copper Alloy and Gold plated per MIL-G-45204.
- Engaging Nut: Delrin® (DuPont trademark for Acetal Resin) (XSJ-CCP).
- O-ring: Nitrile (formerly known as Buna N).
- Specifications:
 - Pressure: Atmospheric to 10,000 psi mated.
 - Temperature Range: -57°C to +93°C (-70°F to +200°F).
 - Maximum Cable Diameter: 0.750 (XSJ-CCR) / 0.875 (XSJ-CCP).
- See page 20 for all contact configurations available.

OPTIONS:

- Open face pressure resistance.
- Cable and molding is optional at additional cost.
- Field installable boot available.

**GRE MSXJ SERIES *
MSXJ-BCR**

Stainless Steel Bulkhead Connector Receptacle
Mates with XSJ-CCP
Dummy Connector: XSJ-DSP

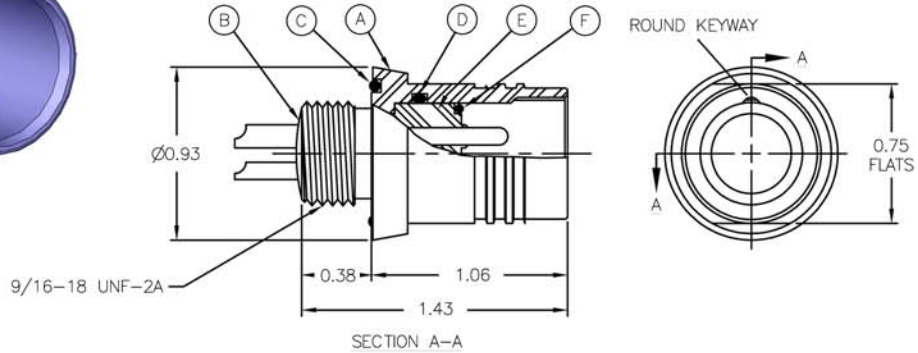
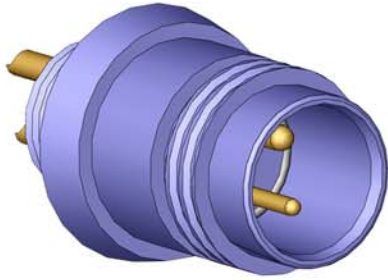

A - CONNECTOR SHELL	B	C - O-RING	D - O-RING	E	F - O-RING
MSXJ-BCR	POTTING	5-254	2-015	MSXJ-CIR	5-058

**GRE XSJJ SERIES
XSJJ-BCR**

GRE Bulkhead Connector Receptacle
Mates with XSJJ-CCP
Dummy Connector: XSJJ-DSP

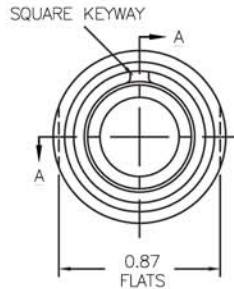
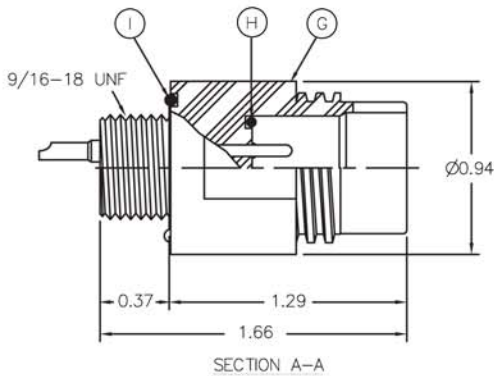

G - CONNECTOR BODY	H - O-RING	I - O-RING
XSJJ-BCR	5-058	5-254

NOTES:

- * Whilst XSJ connectors are still available, they have been superseded by the XSJJ and we recommend the XSJJ for new applications.
- Shell: 316 Stainless Steel, passivated (MSXJ-BCR).
- Body: Glass Reinforced Epoxy B/A XS-2748 (XSJJ-BCR).
- Contacts: Copper Alloy and Gold plated per MIL-G-45204.
- Insert: Glass Reinforced Epoxy B/A XS-2748 (MSXJ-BCR).
- O-ring: Nitrile (formerly known as Buna N).
- Specifications:
 - Pressure: Atmospheric to 10,000 psi mated.
 - Temperature Range: -57°C to +93°C (-70°F to +200°F).
 - Mounting Torque: 20 in-lbs in dry metal threads (XSJJ-BCR).
- See page 20 for all contact configurations available.

OPTIONS:

- 18 inch Teflon® (Registered trademark for DuPont) pigtailed are an option as are customer specified tails.
- Nut and washer set for Bulkhead Connector installation.
- Open face pressure resistance.

GRE XSJJ SERIES XSJJ-CCR

GRE Cable Connector Receptacle
Mates with XSJJ-CCP
Dummy Connector: XSJJ-DSP

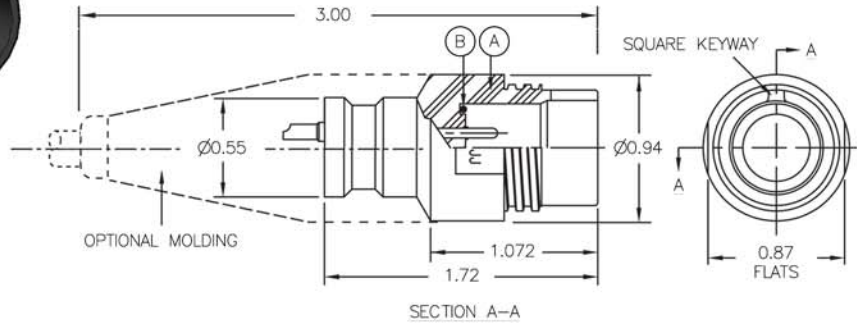
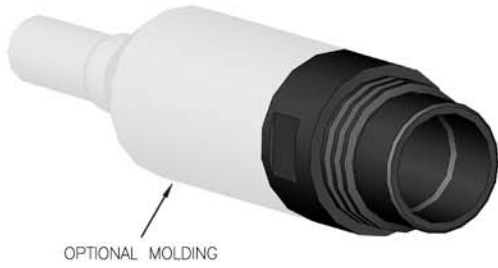

A - CONNECTOR BODY	B
XSJJ-CCR	5-058

GRE XSJJ SERIES XSJJ-CCP

GRE Cable Connector Plug
Mates with XSJJ-BCR/CCR & MSXJJ-BCR
Dummy Connector: XSJJ-DSR

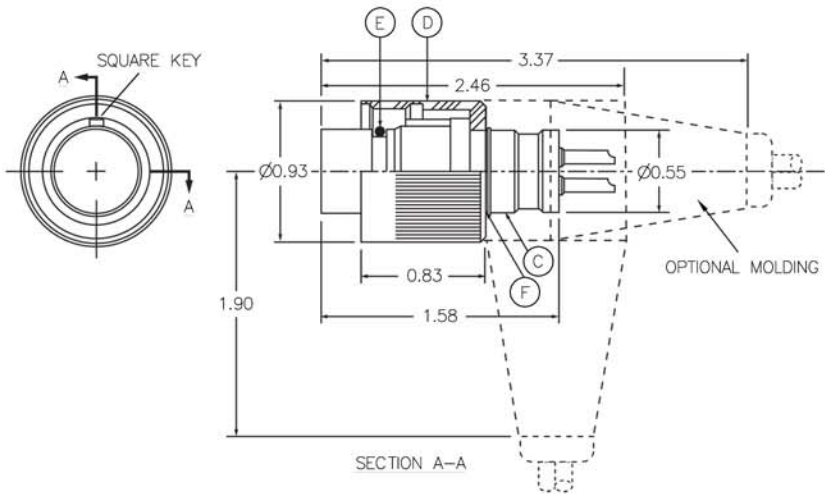

C - CONNECTOR BODY	D	E - O-RING	F - RETAINING RING
XSJJ-CCP	ENGAGING NUT	2-013	5100-55

NOTES:

- Body: Glass Reinforced Epoxy B/A XS-2748.
- Contacts: Copper Alloy and Gold plated per MIL-G-45204.
- Engaging Nut: Delrin® (DuPont trademark for Acetal Resin) (XSJJ-CCP).
- O-ring: Nitrile (formerly known as Buna N).
- Retaining Ring: Stainless Steel, PH 15-7 MO (XSJJ-CCP).
- Specifications:
 - Pressure: Atmospheric to 10,000 psi mated.
 - Temperature Range: -57°C to +93°C (-70°F to +200°F).
 - Mounting Torque: 20 in-lbs in dry metal threads (XSJJ-CCR).
 - Maximum cable diameter: 0.750 (XSJJ-CCR) / 0.875 (XSJJ-CCP).
- See page 20 for all contact configurations available.

OPTIONS:

- Open face pressure resistance.
- Cable and molding is optional at additional cost.

GRE MSXJJ SERIES MSXJJ-BCR

Stainless Steel Bulkhead Connector Receptacle
Mates with XSJJ-CCP
Dummy Connector: XSJJ-DSP

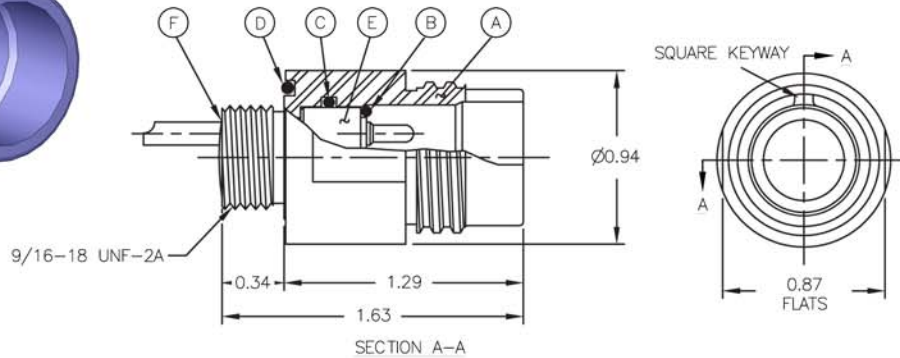
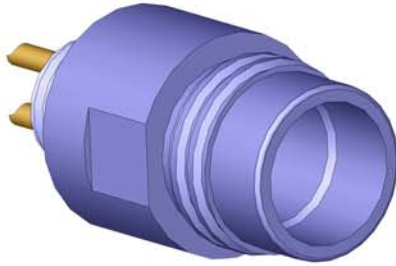

A - CONNECTOR SHELL	B - O-RING	C - O-RING	D - O-RING	E	F
MSXJJ-BCR	5-058	2-015	5-254	MSXJJ-CIR	POTTING

GRE XSL SERIES XSL-BCR

GRE Bulkhead Connector Receptacle
Mates with XSL-CCP & XSL-CCP-FI
Dummy Connector: XSL-DSP

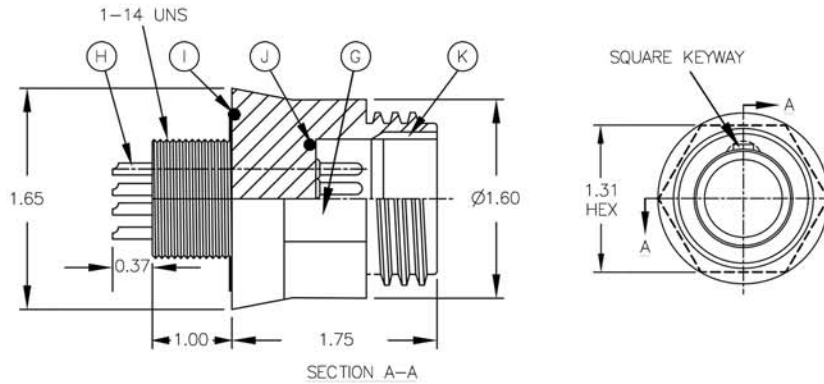

G - CONNECTOR BODY	H	I - O-RING	J - O-RING*	K
XSL-BCR	ELECTRICAL CONTACT (SOLDER POTS)	2-123	2-016	KEYWAY

NOTES:

- Shell: 316 Stainless Steel, passivated (MSXJJ-BCR).
- Body: Glass Reinforced Epoxy B/A XS-2748 (XSL-BCR).
- Contacts: Copper Alloy and Gold plated per MIL-G-45204.
- O-ring: Nitrile (formerly known as Buna N).
- Insert: Glass Reinforced Epoxy B/A XS-2748 (MSXJJ-BCR).
- Back Potting: White Epoxy (MSXJJ-BCR).
- Specifications:
 - Pressure: Atmospheric to 10,000 psi mated (MSXJJ-BCR) / 20,000 psi mated (XSL-BCR).
 - Temperature Range: -57°C to +93°C (-70°F to +200°F).
 - Mounting Torque: 20 in-lbs in dry metal threads (MSXJJ-BCR) / 130 in-lbs in dry metal threads (XSL-BCR).
- * XSL-20-BCR utilizes o-ring 5-254.
- See page 20 for all contact configurations available.

OPTIONS:

- 18 inch Teflon® (Registered trademark for DuPont) pigtailed are an option as are customer specified tails.
- Nut and washer set for Bulkhead Connector installation.
- Open face pressure resistance.

GRE XSL SERIES XSL-CCR

GRE Cable Connector Receptacle
Mates with XSL-CCP & XSL-CCP-FI
Dummy Connector: XSL-DSP

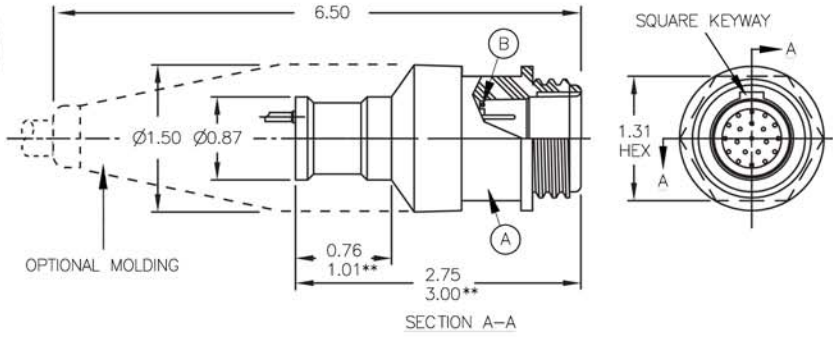
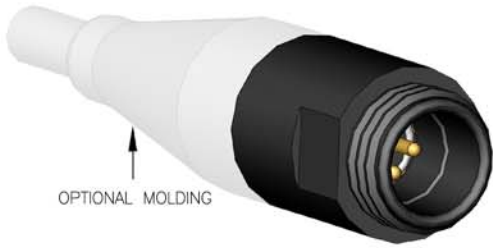

A - CONNECTOR BODY	B - O-RING*
XSL-CCR	2-016

GRE XSL SERIES XSL-CCP

GRE Cable Connector Plug
Mates with XSL-BCR/CCR & MSXL-BCR & XSL-CCR-FI
Dummy Connector: XSL-DSR

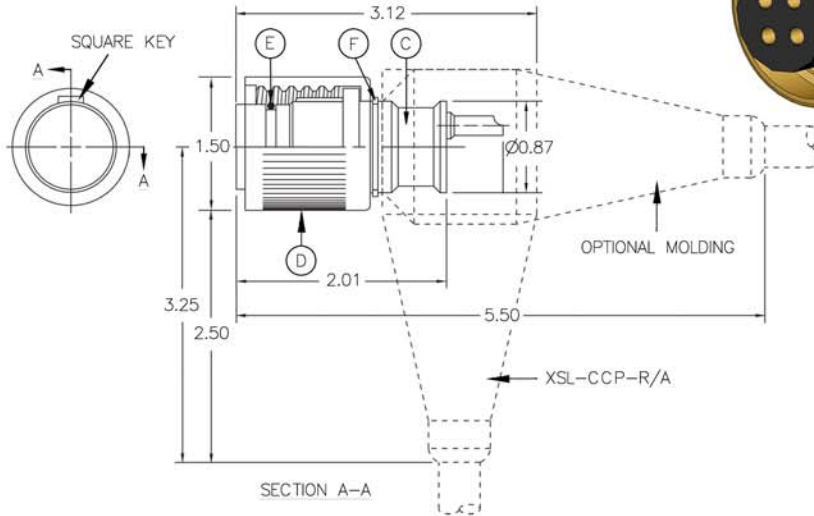
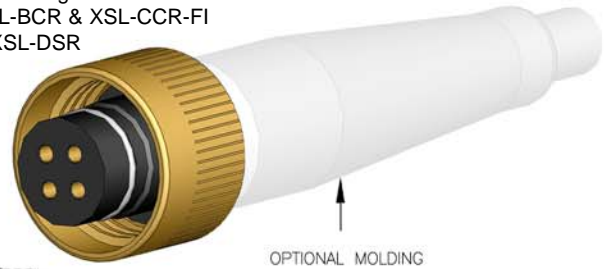

C - CONNECTOR BODY	D	E - O-RING	F - RETAINING RING
XSL-CCP	ENGAGING NUT	2-017	5100-87

NOTES:

- Body: Glass Reinforced Epoxy B/A XS-2748.
- Contacts: Copper Alloy and Gold plated per MIL-G-45204.
- O-ring: Nitrile (formerly known as Buna N).
- Engaging Nut: Delrin® (DuPont trademark for Acetal Resin) (XSL-CCP).
- Retaining Ring: Stainless Steel, PH 15-7 MO (XSL-CCP).
- Specifications:
 - Pressure: Atmospheric to 20,000 psi mated.
 - Temperature Range: -57°C to +93°C (-70°F to +200°F).
 - Maximum Cable Diameter: 0.87 (includes XSL-CCP-R/A).
- * XSL-20-CCR utilizes o-ring 5-254.
- ** XSL-20-CCR dimensions only.
- See page 20 for all contact configurations available.

OPTIONS:

- Open face pressure resistance.
- Cable and molding is optional at additional cost.

GRE FIELD INSTALLABLE SERIES XSL-CCP-FI

GRE Cable Connector Plug
Mates with XSL-BCR/CCR & MSXL-BCR & XSL-CCR-FI
Dummy Connector: XSL-DSR

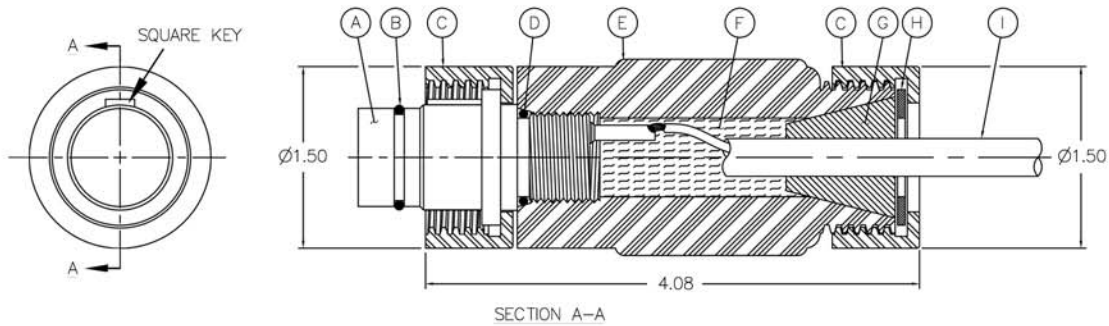

A - CONNECTOR BODY	B - O-RING	C - ENGAGING NUT	D - O-RING	E	F	G	H	I
XSL-CCP-FI	2-017	DELTRIN®*	2-114	XSL-FI HOUSING	POTTING COMPOUND	XSL-FI GROMMET	XSL-FI WASHER	CABLE

GRE FIELD INSTALLABLE SERIES XSL-CCR-FI

GRE Cable Connector Receptacle
Mates with XSL-CCP & XSL-CCP-FI
Dummy Connector: XSL-DSP

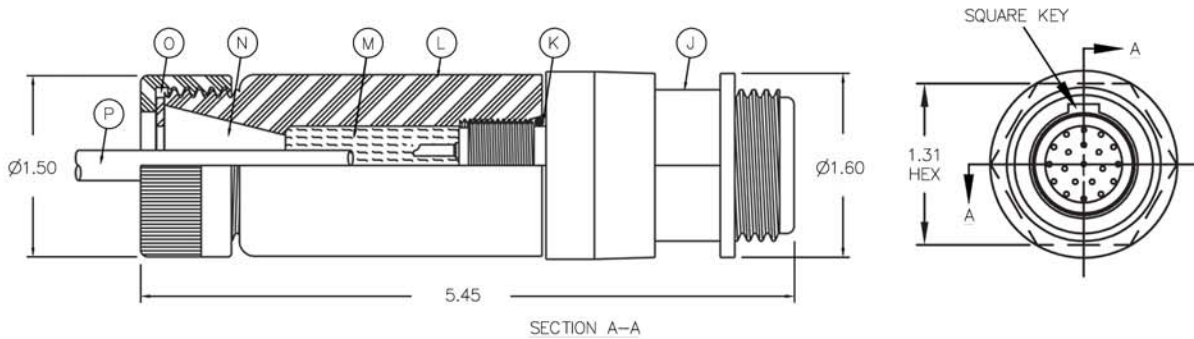

J - CONNECTOR BODY	K	L	M	N	O	P
XSL-CCR-FI	2-114	XSL-FI HOUSING	POTTING COMPOUND	XSL-FI GROMMET	XSL-FI WASHER	CABLE

NOTES:

- This field installable series is available in XSL and XSM sizes. Available as complete kits if desired including connector bodies, component hardware and pre-packaged, ready-to-use injection material. (Cables available on request). Designed for in-the-field assembly - applications to offshore oil filled and oceanographic uses.
- Body: Glass Reinforced Epoxy B/A XS-2748.
- Contacts: Copper Alloy and Gold plated per MIL-G-45204.
- O-ring: Nitrile (formerly known as Buna N).
- Engaging Nut: Delrin® (DuPont trademark for Acetal Resin).
- Housing: Glass Reinforced Epoxy B/A XS-2748.
- Grommet: Neoprene.
- Washer: Delrin® (DuPont trademark for Acetal Resin).
- Cable (Neoprene or Polyurethane) should be cleaned and prepared prior to assembly to insure adhesion.
- Specifications:
 - Pressure: Atmospheric to 20,000 psi mated.
 - Temperature Range: -57°C to +93°C (-70°F to +200°F).
 - Maximum Cable Diameter: 0.62. Cable diameter must be specified at time of order.
- See page 20 for all contact configurations available.
- XSL series FI available thru to 12 contact configurations. Not available in 20 contact version.
- * DuPont trademark for Acetal Resin.

OPTIONS:

- Open face pressure resistance.
- Cable and molding is optional at additional cost.

GRE MSXL SERIES MSXL-BCR

GRE Bulkhead Connector Receptacle
Mates with XSL-CCP
Dummy Connector: XSL-DSP

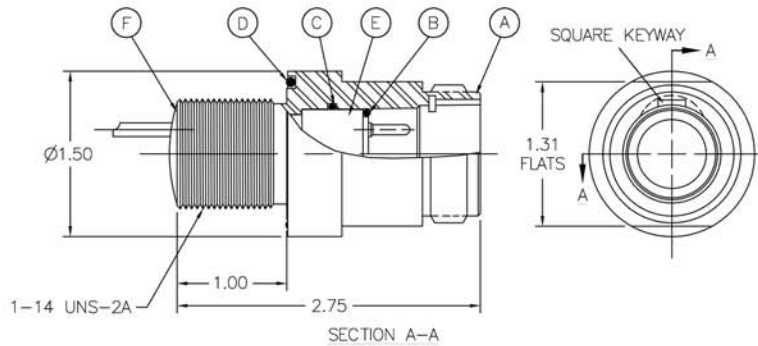
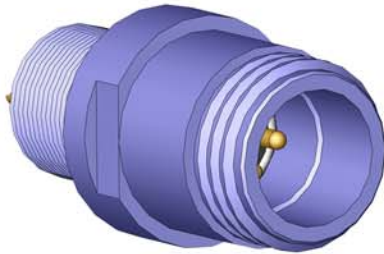

A - CONNECTOR SHELL	B - O-RING	C - O-RING	D - O-RING	E	F
MSXL-BCR	2-017	2-019	2-123	MSXL-CIR	POTTING

GRE PBOF SERIES XSL-BCR-PBOF

GRE Bulkhead Connector Receptacle Pressure Balanced Oil Filled
Mates with XSL-CCP-PBOF
Dummy Connector: XSL-DSP-PBOF

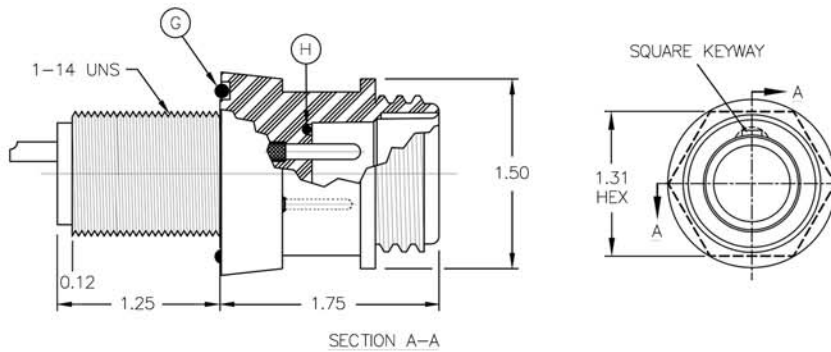

CONNECTOR BODY	G - O-RING	H - O-RING
XSL-BCR-PBOF	2-123	2-016

NOTES:

- Shell: 316 Stainless Steel, passivated (MSXL-BCR).
- Body: Glass Reinforced Epoxy B/A XS-2748 (XSL-BCR-PBOF).
- Contacts: Copper Alloy and Gold plated per MIL-G-45204.
- Insert: Glass Reinforced Epoxy B/A XS-2748 (MSXL-BCR).
- O-ring: Nitrile (formerly known as Buna N).
- Internal o-ring is 2-016 for all patterns, however XSL-12 and 20 utilize o-ring 5-254 (XSL-BCR-PBOF).
- Specifications:
 - Pressure: Atmospheric to 20,000 psi mated (MSXL-BCR) / 10,000 psi mated (XSL-BCR-POF).
 - Temperature Range: -57°C to +93°C (-70°F to +200°F).
 - Mounting Torque: 130 in-lbs in dry metal threads.
- See page 20 for all contact configurations available.

OPTIONS:

- 18 inch Teflon® (Registered trademark for DuPont) pigtailed are an option as are customer specified tails.
- Nut and washer set for Bulkhead Connector installation.
- Open face pressure resistance (MSXL-BCR).

GRE PBOF SERIES XSL-CCP-PBOF

GRE Cable Connector Plug Pressure Balanced Oil Filled
Mates with XSL-BCR-PBOF
Dummy Connector: XSL-DSR-PBOF

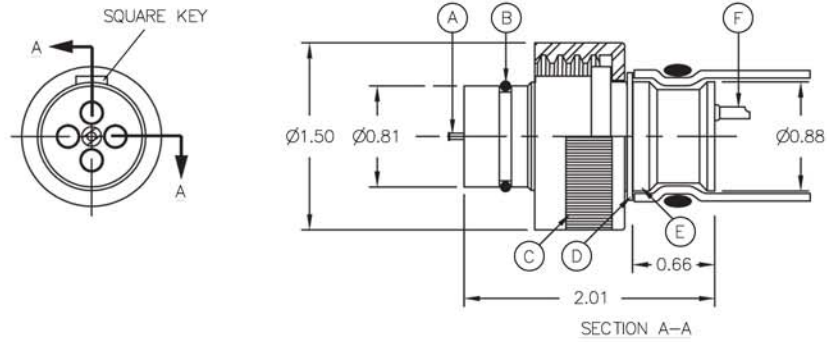

CONNECTOR BODY	A	B - O-RING	C	D	E	F
XSL-CCP-PBOF	OIL COMPENSATED VALVE	2-017	ENGAGING NUT	RETAINING RING	DIAMETER ON BODY FOR TUBING TERMINATION	SOLDER POTS

GRE XSM SERIES XSM-BCR

GRE Bulkhead Connector Receptacle
Mates with XSM-CCP & XSM-CCP-FI
Dummy Connector: XSM-DSP

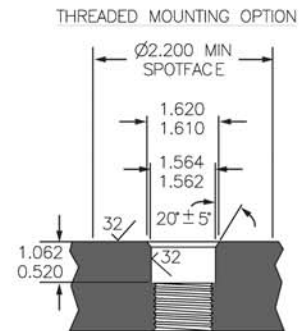
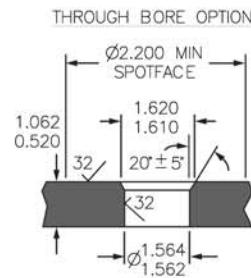
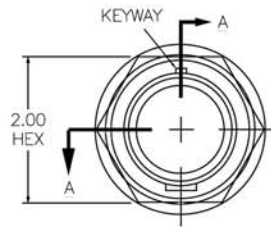
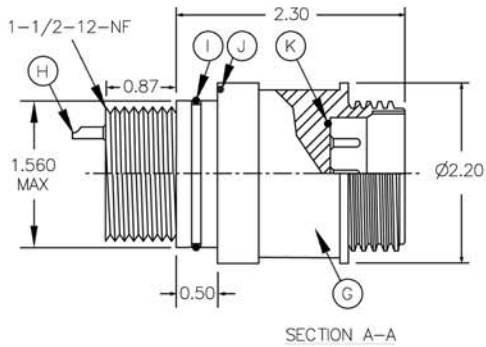

G - CONNECTOR BODY	H	I - O-RING	J - O-RING	K - O-RING
XSM-BCR	ELECTRICAL CONTACT	2-126	2-132	2-122

NOTES:

- Body: Glass Reinforced Epoxy B/A XS-2748.
- Contacts: Copper Alloy and Gold plated per MIL-G-45204.
- O-ring: Nitrile (formerly known as Buna N).
- Internal o-ring is 2-016 for all patterns, however XSL-12 and 20 utilize o-ring 5-254 (XSL-CCP-PBOF).
- Engaging Nut: Delrin® (DuPont trademark for Acetal Resin) (XSL-CCP-PBOF).
- Retaining Ring: Stainless Steel, PH 15-7 MO (XSL-CCP-PBOF).
- Recommended Tubing Size: 0.75 ID (Tubing not supplied with parts unless specified) (XSL-CCP-PBOF).
- Specifications:
 - Pressure: Atmospheric to 10,000 psi mated.
 - Temperature Range: -57°C to +93°C (-70°F to +200°F).
 - Mounting Torque: 200 in-lbs in dry metal threads (XSM-BCR).
- See page 20 for all contact configurations available.

OPTIONS:

- 18 inch Teflon® (Registered trademark for DuPont) pigtailed are an option as are customer specified tails.
- Nut and washer set for Bulkhead Connector installation.
- Open face pressure resistance (XSM-BCR).

GRE XSM SERIES XSM-CCR

GRE Cable Connector Receptacle
Mates with XSM-CCP & XSM-CCP-FI
Dummy Connector: XSM-DSP

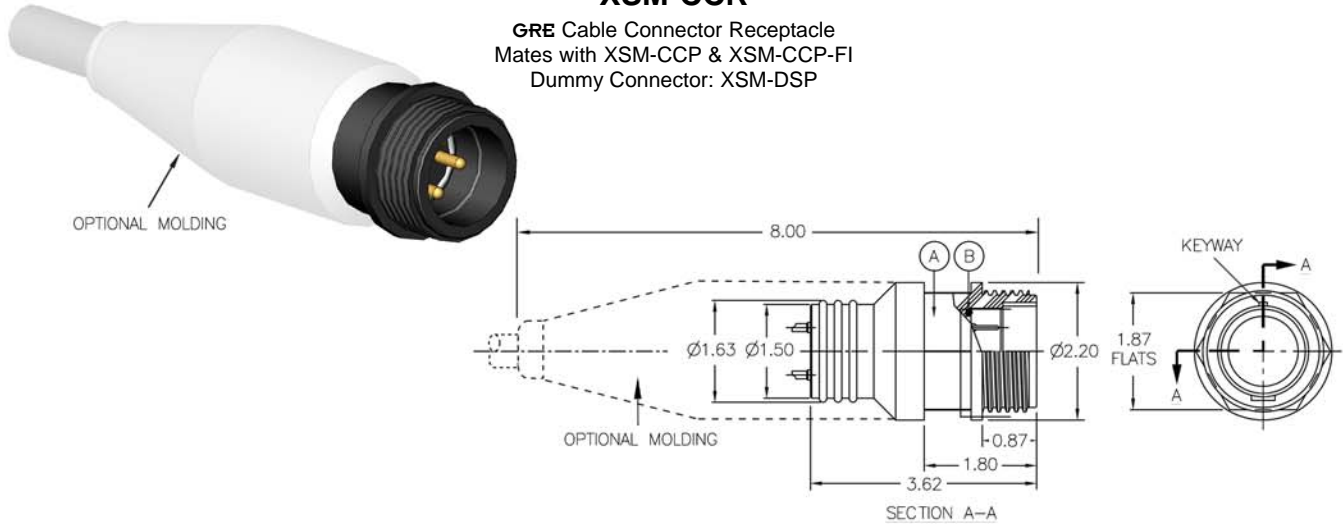

A - CONNECTOR BODY	B - O-RING
XSM-CCR	2-122

GRE XSM SERIES XSM-CCP

GRE Cable Connector Plug
Mates with XSM-BCR/CCR & MSXM-BCR & XSM-CCR-FI
Dummy Connector: XSM-DSR

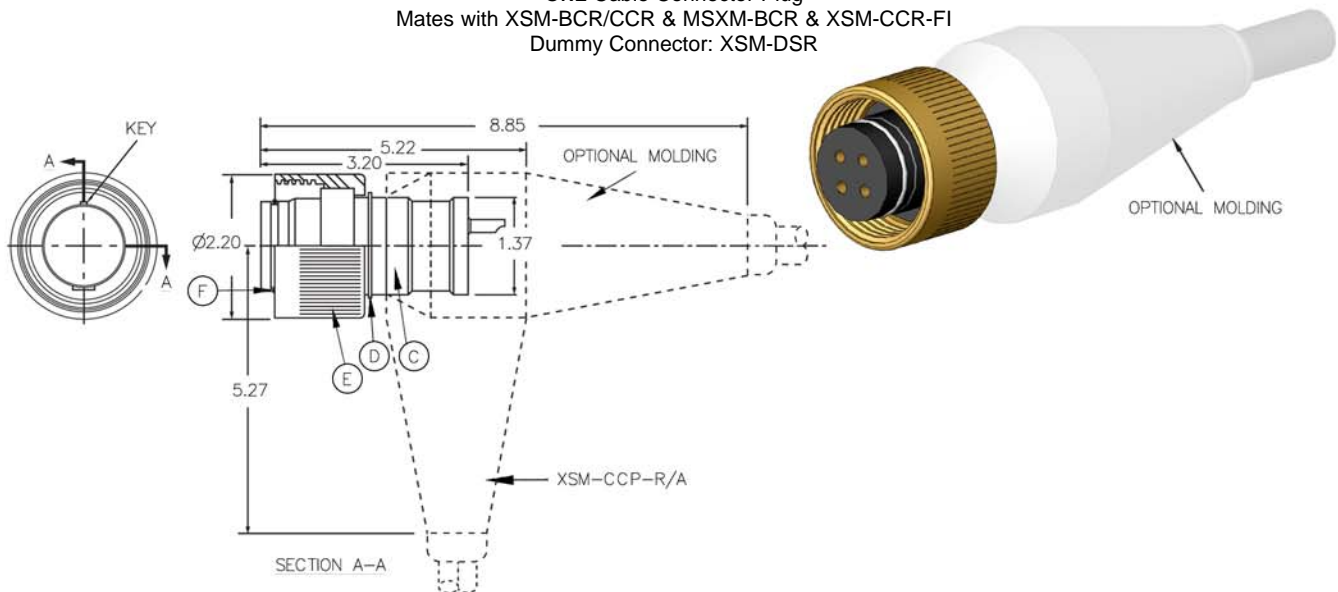

C - CONNECTOR BODY	D - RETAINING RING	E - ENGAGING NUT	F - O-RING
XSM-CCP	5600-137H	STAINLESS STEEL	2-026

NOTES:

- Body: Glass Reinforced Epoxy B/A XS-2748.
- Contacts: Copper Alloy and Gold plated per MIL-G-45204.
- O-ring: Nitrile (formerly known as Buna N).
- Retaining Ring: Stainless Steel, PH 15-7 MO (XSM-CCP).
- Specifications:
 - Pressure: Atmospheric to 10,000 psi mated.
 - Temperature Range: -57°C to +93°C (-70°F to +200°F).
 - Maximum Cable Diameter: 1.125.
- See page 20 for all contact configurations available.

OPTIONS:

- Open face pressure resistance.
- Cable and molding is optional at additional cost.

GRE FIELD INSTALLABLE SERIES XSM-CCP-FI

GRE Cable Connector Plug
Mates with XSM-BCR/CCR & XSM-CCR-FI
Dummy Connector: XSM-DSR

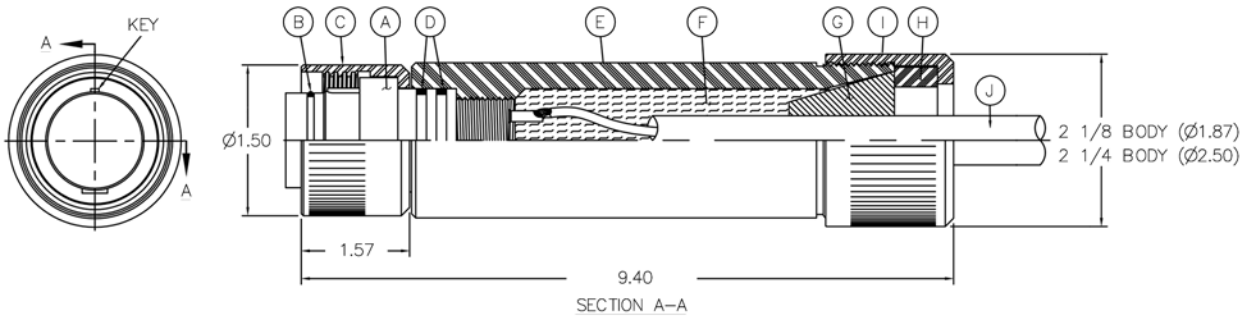

A - CONNECTOR BODY	B - O-RING	C - ENGAGING NUT	D - O-RING	E	F	G	H	I - TORQUE NUT	J - CABLE Ø (INCHES)
XSM-CCP-FI	2-026	STAINLESS STEEL	2-125	2 1/8 BODY XSM-FI HOUSING	POTTING COMPOUND	2 1/8 BODY XSM-FI GROMMET	2 1/8 BODY XSM-FI WASHER	MSSK E/N	< than 1.00
XSM-CCP-FI	2-026	STAINLESS STEEL	2-125	2 1/4 BODY XSM-FI HOUSING	POTTING COMPOUND	2 1/4 BODY XSM-FI GROMMET	2 1/4 BODY XSM-FI WASHER	MSSM E/N	1.00 - 1.37

GRE FIELD INSTALLABLE SERIES XSM-CCR-FI

GRE Cable Connector Receptacle
Mates with XSM-CCP & XSM-CCP-FI
Dummy Connector: XSM-DSP

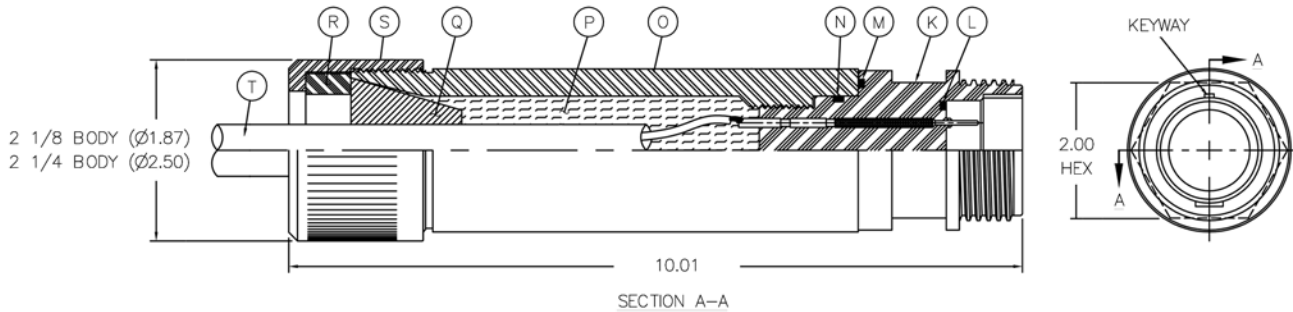

K - CONNECTOR BODY	L - O-RING	M - O-RING	N - O-RING	O	P	Q	R	S - TORQUE NUT	T - CABLE Ø (INCHES)
XSM-CCP-FI	2-122	2-132	2-125	2 1/8 BODY XSM-FI HOUSING	POTTING COMPOUND	2 1/8 BODY XSM-FI GROMMET	2 1/8 BODY XSM-FI WASHER	MSSK E/N	< than 1.00
XSM-CCP-FI	2-122	2-132	2-125	2 1/4 BODY XSM-FI HOUSING	POTTING COMPOUND	2 1/4 BODY XSM-FI GROMMET	2 1/4 BODY XSM-FI WASHER	MSSM E/N	1.00 - 1.37

NOTES:

- This field installable series is available in XSL and XSM sizes. Available as complete kits if desired including connector bodies, component hardware and pre-packaged, ready-to-use injection material. (Cables available on request). Designed for in-the-field assembly - applications to offshore oil filled and oceanographic uses.
- Body: Glass Reinforced Epoxy B/A XS-2748.
- Contacts: Copper Alloy and Gold plated per MIL-G-45204.
- O-ring: Nitrile (formerly known as Buna N).
- Engaging Nut: 316 Stainless Steel (XSM-CCP-FI) / Delrin® (DuPont trademark for Acetal Resin) (XSM-CCR-FI).
- Housing: Delrin® (DuPont trademark for Acetal Resin).
- Grommet: Neoprene.
- Washer: Delrin® (DuPont trademark for Acetal Resin).
- Cable (Neoprene or Polyurethane) should be cleaned and prepared prior to assembly to insure adhesion.
- Specifications:
 - Pressure: Atmospheric to 10,000 psi mated.
 - Temperature Range: -57°C to +93°C (-70°F to +200°F).
 - Maximum Cable Diameter: Please see table above. Cable diameter must be specified at time of order.
- See page 20 for all contact configurations available.

OPTIONS:

- Open face pressure resistance.
- Cable and molding is optional at additional cost.

GRE MSXM SERIES MSXM-BCR

Stainless Steel Bulkhead Connector Receptacle
Mates with XSM-CCP & XSM-CCP-FI
Dummy Connector: XSM-DSP

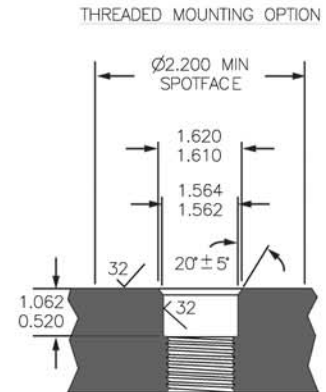
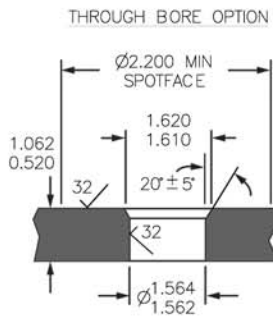
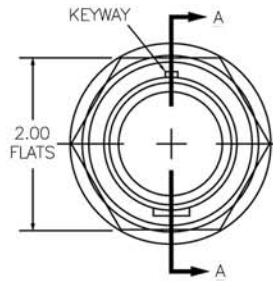
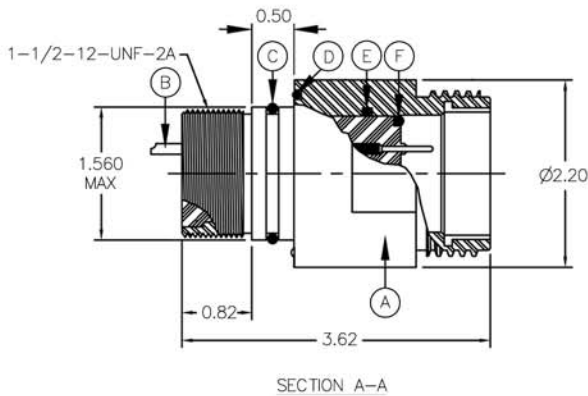
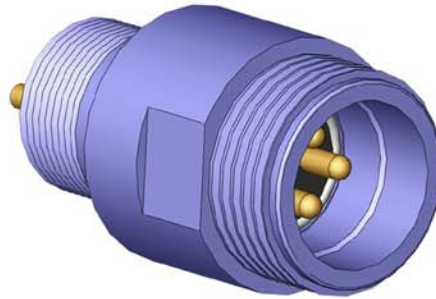

A - CONNECTOR SHELL	B	C - O-RING	D - O-RING	E - O-RING	F - O-RING
MSXM-BCR	ELECTRICAL CONTACT	2-126	2-132	2-126	2-122

NOTES:

- Shell: 316 Stainless Steel, passivated.
- Contacts: Copper Alloy and Gold plated per MIL-G-45204.
- Insert: Glass Reinforced Epoxy B/A XS-2748.
- O-ring: Nitrile (formerly known as Buna N).
- Specifications:
 - Pressure: Atmospheric to 10,000 psi mated.
 - Temperature Range: -57°C to +93°C (-70°F to +200°F).
 - Mounting Torque: 200 in-lbs in dry metal threads.
- See page 20 for all contact configurations available.

OPTIONS:

- 18 inch Teflon® (Registered trademark for DuPont) pigtailed are an option as are customer specified tails.
- Nut and washer set for Bulkhead Connector installation.
- Open face pressure resistance.

SIZE	GRE SERIES CONTACT CONFIGURATIONS (MALE FACE VIEW ONLY - NOT TO SCALE)*						
XSEE							
	20 ohm COAX 1,000 VDC	1#8 ** 1,000 VDC	2#14 800 VDC	3#14 700 VDC	4#14 600 VDC	6#16 500 VDC	7#16 500 VDC
MSXEE							
	8#20 400 VDC	10#20 300 VDC	12#20 250 VDC				
XSJ							
	20 ohm COAX *** 1,000 VDC	1#14/1#16 (2) 600 VDC	1#14/2#16 (3) 600 VDC	1#14/3#16 (4) 300 VDC	2#16/3#20 (5) 300 VDC	1#16/6#20 (7) 300 VDC	1#14/8#20 (9) 300 VDC
XSL							
	1#8/1#10 (2) 1,200 VDC	4#10 800 VDC	1#14/4#16 (5) 800 VDC	6#16 600VDC	3#8/3#20 (6) 600 VDC	8#16 600 VDC	10#16 400 VDC
MSXL							
	12#16 300 VDC	20#20 200 VDC					
XSL PBOF							
	4#10 800 VDC	1#14/4#16 (5) 800 VDC	3#10/3#20 (6) **** 300 VDC	7#16 600 VDC	1#14/7#16 (8) 300 VDC	2#10/6#20 (8) 300 VDC	3#16/9#20 (12) 300 VDC
XSM							
	1#1/0 2,800 VDC	4#6 2,000 VDC	4A#4 ***** 2,000 VDC	6#10 2,000 VDC	8#14 1,600 VDC	12#14 900 VDC	16#14 700 VDC
MSXM							
	24#16 600 VDC	36#16 600 VDC					

NOTES:

• Current ratings maybe impacted by cable selection.

• * For female face view contact configurations available please contact SEA CON®.

• ** Currently not available in MSXEE-BCR.

• *** Currently not available in XSJJ/MSXJJ.

• **** Currently not available in MSXL-BCR.

• ***** Currently not available in XSM-BCR.

**THE FOLLOWING GLASS REINFORCED EPOXY
BULKHEAD CONNECTORS CAN BE FOUND WITH
THEIR RESPECTIVE MATES IN THE
RUBBER MOLDED SECTION**

XSA-BC, XSA-BCL
XSB-BCL
XSC-BC, XSC-BCL

VSA-BC, VSA-BCL
VSB-BCL,
VSC-BC, VSC-BCL

XSF-BC, XSF-BCL
XSFDE-BCL (formerly XSDE-BCL)

VSF-BCL

LSG-BC, LSG-BCL
LSG-BC HP
LSG-BC SC (formerly LSK-BC-SC)

XSG-BCL, XSG-BCL-P-R/A
XSG-PBC, XSG-PBCL, XSG-PBCLM

VSG-BCL
VSG-PBC, VSG-PBCL, VSG-PBCLM

XSK-BCL
XSKDE-BCL

VSK-BCL

HANDLING PROCEDURES AND SPECIAL CAPABILITIES

SEA CON® SEA CON®
1700 Gillespie Way,
El Cajon, California 92020, USA.
TEL: +1 (619) 562-7071
FAX: +1 (619) 562-9706
E-Mail: seacon@seacon-usa.com
Website: www.seaconworldwide.com

SEA CON® SEA CON US GULF AREA SALES OFFICE
21925 Franz Road, Suite 401,
Katy, Texas 77449, USA.
TEL: +1 (281) 599-3509
FAX: +1 (281) 599-3517
E-Mail: gulfcoastsales@seaconbrantner.com
Website: www.seaconworldwide.com

SEA CON® SEA CON US EAST COAST SALES OFFICE
50 Airport Road,
Westerly, RI 02891, USA.
TEL: +1 (401) 348-0155
FAX: +1 (401) 348-0227
E-Mail: eastcoastsales@seaconbrantner.com
Website: www.seaconworldwide.com

SEA CON® SEA CON FLORIDA SALES OFFICE
Building B, Suite 22,
3959 South Nova Road,
Port Orange,
Florida 32127, USA.
TEL: +1 (281) 802-5504
E-Mail: steven.thumbek@seacon-ap.com

SEA CON advanced SEA CON ADVANCED PRODUCTS, LLC
1321 Nelius Road, P.O. Box 767,
Bellville, Texas 77418, USA.
TEL: +1 (979) 865-8846
FAX: +1 (979) 865-8859
E-Mail: sales@seacon-ap.com
Website: www.seacon-ap.com

SEA CON brazil SEA CON BRAZIL
Rua Conde de Bonfim 120 sala 212,
Tijuca, Rio de Janeiro,
Brazil, CEP: 20520-053.
TEL: +55 (21) 8849-3336
E-Mail: renata@seacon-ap.com

SEA CON europe SEA CON (europe) LTD
Seacon House, Hewett Road,
Gapton Hall Industrial Estate,
Great Yarmouth, Norfolk, NR31 0RB, UK.
TEL: +44 (0) 1493-652733
FAX: +44 (0) 1493-652840
E-Mail: sales@seaconeurope.com
Website: www.seaconeurope.com

SEA CON global SEA CON GLOBAL PRODUCTION
Callejon Terrazos #8, Local 2-C,
Las Brisas 1ra. Seccion,
Tijuana, B.C., Mexico C.P. 22610.
TEL: +52 (664) 626-2726
FAX: +52 (664) 686-8922
E-Mail: sales@seaconglobal.com
Website: www.seaconglobal.com
Dial from U.S.A. TEL: +1 (619) 308-7901
TOLL FREE: (888) 562-7072
FAX: +1 (619) 308-7900

SEA CON phoenix SEA CON PHOENIX, LLC
15 Gray Lane, Suite 108,
Hopkinton Industrial Park,
Ashaway, RI 02804, USA.
TEL: +1 (401) 637-4952
FAX: +1 (401) 637-4953
E-Mail: sales@seaconphoenixllc.com
Website: www.seaconphoenixllc.com

Even though these procedures appear simple, only qualified technicians should perform the installation and maintenance.

Connectors are designed for installation on one atmosphere vessels. Contact **SEA CON®** for recommendations if using compensated vessels.

CARE AND MAINTENANCE

The following procedure details the maintenance requirements for **GRE** connectors. The major requirements are cleanliness and o-ring replacement. When left mated there is no maintenance. If connectors are periodically unmated **SEA CON®** recommends a new o-ring be installed.

- Before un mating ensure connectors are free of foreign contaminants. Visually check for and note any damage or abnormalities.
- After un mating visually check for and note any damage, cut o-ring or abnormalities.
- Remove o-ring. Use caution to avoid damaging o-ring sealing surface. Use only the highest quality o-ring extraction tool (available from o-ring distributors).
- Clean any grease, moisture or foreign particles from inside connector, including the o-ring groove and sealing area.
- In the event the internal contact surfaces are dirty or have been exposed to water the plug connector should be flushed with distilled or deionized water and thoroughly dried.
- The surface should be dried using a low pressure (15-25 psi) gas stream of dry nitrogen or filtered compressed air (dry nitrogen is preferred). This drying procedure ensures the removal of any small foreign particles.

- Electrically test the connector in accordance with the parameters of the system.

- Inspect the replacement o-ring for any damage or abnormalities. Lubricate the o-ring with an appropriate silicone grease or spray and install it using two orange sticks (orange sticks are a non-conductive, soft and pliable orangewood soldering production aid, approximately 3/16" in diameter and 7" long, available from soldering supply distributors). Apply a very thin film of an appropriate silicone grease or spray to the o-ring sealing surfaces. Cover/protect cable plug from foreign contaminants until ready to mate.

CABLE AND CONTINUITY PRESERVATION

Avoid sharp bends in cables. Cables subjected to vibration and exposed to seawater drag should be adequately clamped to prevent fatigue and possible failure.

All reasonable efforts have been taken to ensure that the information contained herein is accurate at the date of publication, but no representation or warranty as to the accuracy or completeness of such information is intended or to be implied by its inclusion herein. Any and all representations and warranties pertaining to the information and products referred to herein shall be set forth in **SEA CON®** standard sales order form. In addition, **SEA CON®** reserves the right to make changes to the contents hereof without notice, therefore it is suggested that at the time of inquiry, the appropriate sales office or factory be contacted directly for verification of published specifications and products availability.

© 2011 **SEA CON®**
ALL RIGHTS RESERVED